



**TEAM
RC10
CAR**
INSTRUCTION MANUAL



32 TEAM ASSOCIATED

The New RC10 Team Car's Latest Technology

NEW STEALTH TRANSMISSION

NEW DUST COVER

**NEW TURNBUCKLES,
FRONT AND REAR**

NEW LOW PROFILE REAR WHEELS

NEW LOW PROFILE REAR TIRES

NEW REAR UNIVERSAL-DOGBONE/STUB AXLE

NEW ONE-PIECE, LOW PROFILE FRONT WHEELS

NEW VIPER BODY

**NEW INLINE FRONT AXLE
AND STEERING BLOCKS**

**NEW HARD ANODYZED, TEFLON COATED SHOCKS
AND NEW SPRINGS FRONT AND REAR**

NEW REAR HUB CARRIERS

NEW FRONT SHOCK TOWER

NEW SHOCK MOUNTING POSITIONS

NEW LONGER FRONT SHOCKS

NEW BLACK ANODYZED CHASSIS

NEW LONGER FRONT A-ARMS

NEW LOW PROFILE FRONT TIRES



Advanced, Competition Version of the RC10

FIRST, A WORD

Your RC10 Team Car is the latest state-of-the-art, 2WD off-road racer in the world. There is none better.

Our original RC10 car has won more IFMAR World Championships and ROAR Nationals than all the other 2WD off-road winning cars put together. It is by far the most popular 2WD off-road RACE car in the world. The READERS of RC CAR ACTION magazine voted the RC10 as CAR OF THE YEAR by a 6 to 1 margin over the 2nd place car! The racers know which car is best.

As great as the original RC10 is, we wanted something better, and we know you did too, so we've brought out the new RC10 Team Car. At first glance it looks like an RC10. But it's much more than that. It has NEW longer front A-arms with two NEW shock mounting positions. NEW inline front axle and steering blocks which greatly improve the steering. NEW front shock towers which give more ideal shock mounting positions. NEW rear universal-dog-bone driveshaft, giving freer suspension and eliminating lost dogbones. NEW rear hub carriers with more toe-in for greater stability. NEW turnbuckles for easier adjustments. NEW low profile front and rear wheels and tires, giving more steering in the front end and more traction in the rear end.

This kit also contains our NEW STEALTH TRANSMISSION and our newly-designed shock absorbers with hard anodized plating and Teflon coating.

At the 1990 Off Road ROAR Nationals, Team Associated finished 1st, 2nd and 3rd using these new parts. Cliff Lett won the Nats, which didn't surprise anyone, but the big surprise was Brent Wallace and J. D. Beckwith, both who finished 2nd and 3rd at the very first race they ever ran the new STEALTH TRANSMISSION! We are getting similar reports of equal success from racers all around the world after using the STEALTH TRANSMISSION in their older RC10's. But you now have the complete, NEW TEAM CAR and we know this combination will also help you greatly improve your performance. Good luck in your racing!

You'll find the photos in the instructions so easy to follow that you may be tempted to put the car together from the photos alone. However, although you have the best car kit, if you want the best COMPLETED model race car, then you will want to put it together correctly—by following these instructions. All that's required is to read the few lines of text near each photo.

DON'T OPEN ANY OF THE PARTS BAGS UNTIL THESE INSTRUCTIONS TELL YOU, otherwise you'll get the parts mixed up and then you will have trouble assembling your car.

While you are building the car you will sometimes be working with several parts bags at the same time. These bags are referred to by number in the instructions, and you will find a number label on each of the main parts

bags. There are also more bags inside the main parts bags; these are not numbered and belong to the bag they came out of.

Bags and parts will start multiplying like rabbits as you build, so try to keep the bags separate. One good way is to use large paper plates (picnic plates with partitions are best). Mark the plates with bag numbers and dump the parts into them. When the parts are used up, relabel the plate for another bag. It's much easier to find the part you need if it's spread out where you can see it.

TOOLS. The kit contains the shock wrench and all the Allen wrenches you'll need, but you will have to supply the following:

#2 Phillips screwdriver (Associated #SP76)

A needle-nose pliers

A hobby knife, such as an X-acto with a pointed blade

A soldering iron (25 to 50 watts), and a small amount of ROSIN (not acid) core 60/40 solder.

The kit can be assembled even easier if you have the following:

3/32" straight Allen wrench with handle. Will make installing the Allen screws much faster and easier (Associated #SP73)

A ruler with decimal inches or metric measure

A 3/16" nut driver will make installing the ball ends easier (Associated #SP86)

A 1/4" nut driver will speed up installing the 1/4" nuts (#SP85)

Socket or open-end wrench

Small screwdriver

Thread-locking compound

ZAP or Hot Stuff (cyanoacrylate adhesive)

Vise

File

Drill with #43 (2.3 mm) bit

WARNING! Do not use a power screwdriver. They spin too fast, causing screws to heat up when being driven into plastic and will strip out.

Take your time assembling the car. It's not a race to see how fast you put the car together; it's how well you put it together that determines how fast you'll be able to race.

Boxes at each step are provided so you can put a check mark for each assembly after each step is completed. So when you stop during assembly time, you'll be able to come back and start in the correct step.

One final note for you experienced builders and racers: **please build the car our way first!!** The RC10 Team Car is a remarkably fast car right out of the box. There's a reason for everything on the car, and very few compromises were made in its design. Work with the car first and see what it can do before you experiment or make changes.

Clear off your workbench, line up some paper plates, grab a sandwich, and *let's begin.* . .

□ **Fig. 1** We'll start with fig. 1. Only take the parts out of the bag that we tell you, and no others. Look for Bag #6-4 and take the #6309 black anodized nose piece out of the bag, as shown in the photo, and the shortest Phillips flat head screw, as shown. DO NOT take anything else out of the bag. Now take the 2 Phillips screws out of Bag #6-2, but nothing else.

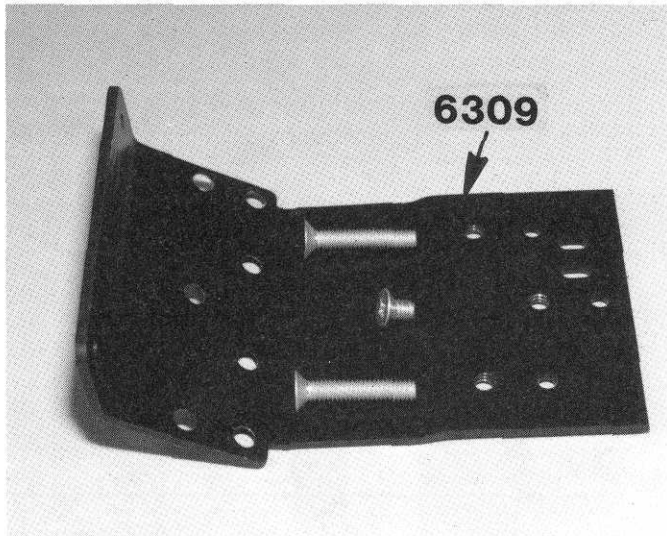

Fig. 1

□ **Fig. 3** In Bag #6-5, take one #6330 body mount, 2 washers and one short screw. (The long screw is used to extend the body mounts for other body styles.)

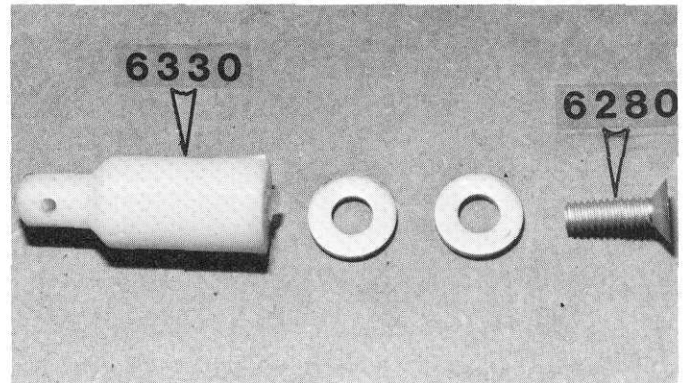

Fig. 3

□ **Fig. 2** Take the black aluminum chassis #6301 and install the nose piece, as shown, with the #2 Phillips screwdriver. Note that all the chassis screws are aluminum and can be easily damaged by a worn screwdriver, Be sure yours is in good condition.

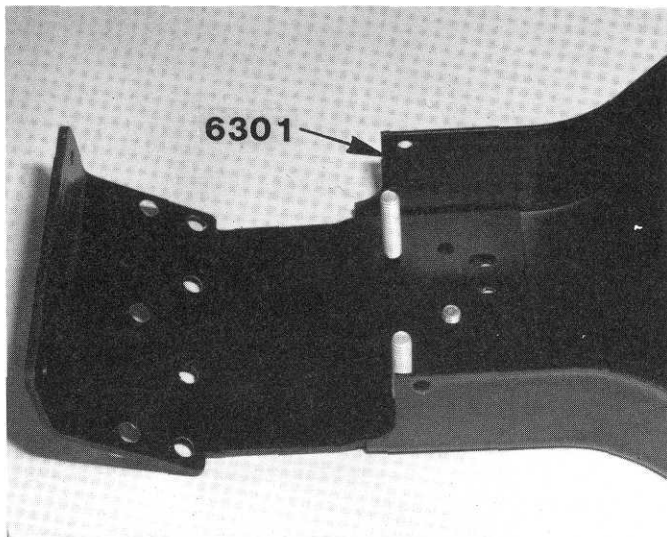

Fig. 2

□ **Fig. 4** Install body mount as shown with body clip hole going left to right.

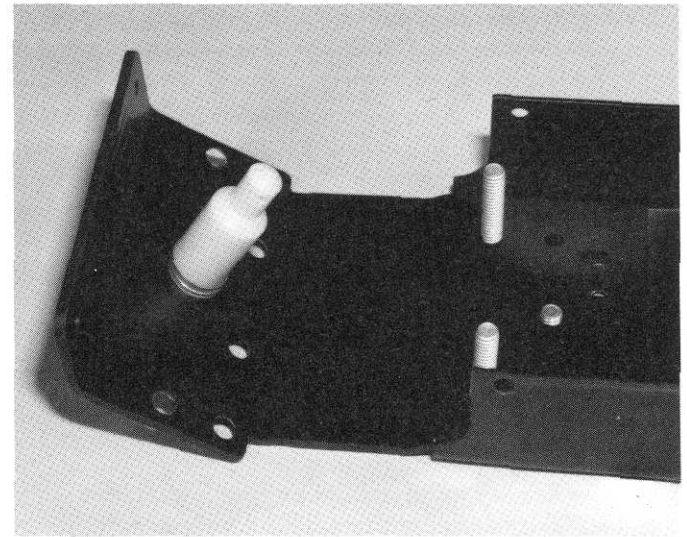

Fig. 4

□ **Fig. 5** In Bag #6-1, take out the left hand front suspension mount #6207. This mount will have the letter L on the bottom. The left or right hand side of the car is determined by the driver as he sits in the car. His left hand will be the left side of the car and his right hand the right side.

NOTE: The left and right front suspension mounts are attached together by a thin "runner" that must be removed with scissors or a knife.

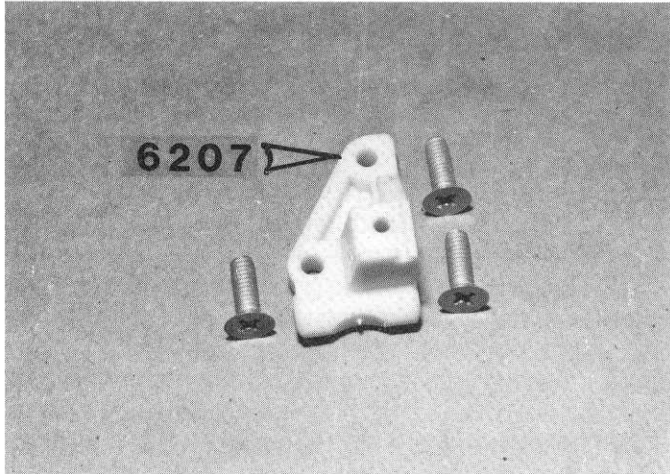

Fig. 5

□ **Fig. 6** Install the L.H. suspension mount, as shown, with the 3 Phillips screws. Now install the right hand mount.

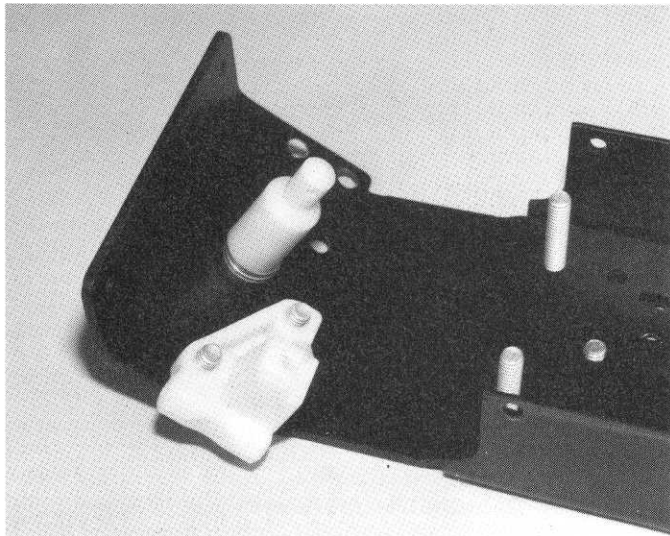

Fig. 6

□ **Figs. 7 & 7a** In the same bag, take out the #6206 L.H. front A-arm, the #6226 inner pin and the package of "E" clips, as shown.

NOTE: The package of "E" clips is in the form of a "stack" or short roll with white paper glued around the outside (see fig. 7a). There is a roll of "E" clips in three different bags. You will have more than enough to complete your car. Slip the pin into each end of the front A-arm #6206 to check the pin fit. The A-arm should be able to swing freely on the pin. Most racers keep a .126" and a .128" reamer in their toolbox to free up A-arms and to clean them after racing. We want the pin to fit tight in the mount #6207.

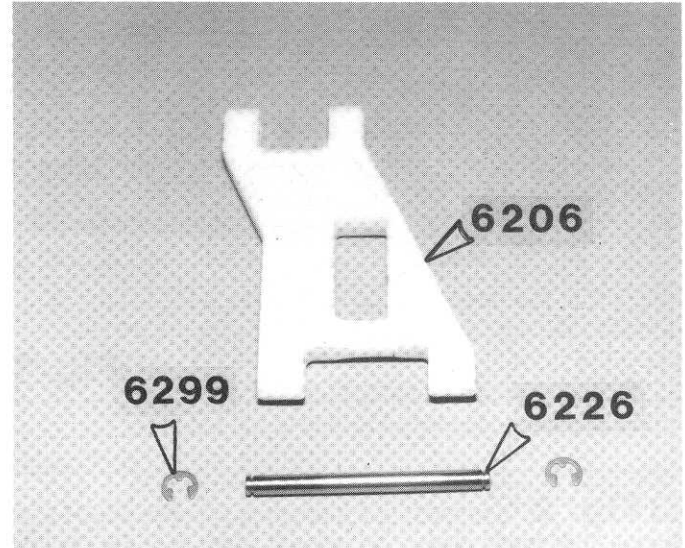

Fig. 7

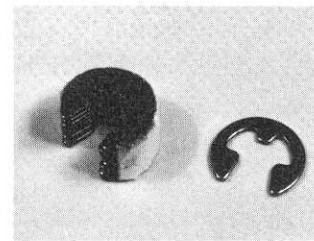

Fig. 7a

□ **Fig. 8** Line up the A-arm with the mount and push the pin through. Using a small screwdriver, install an "E" clip on each end of the pin. Now install the R.H. side.

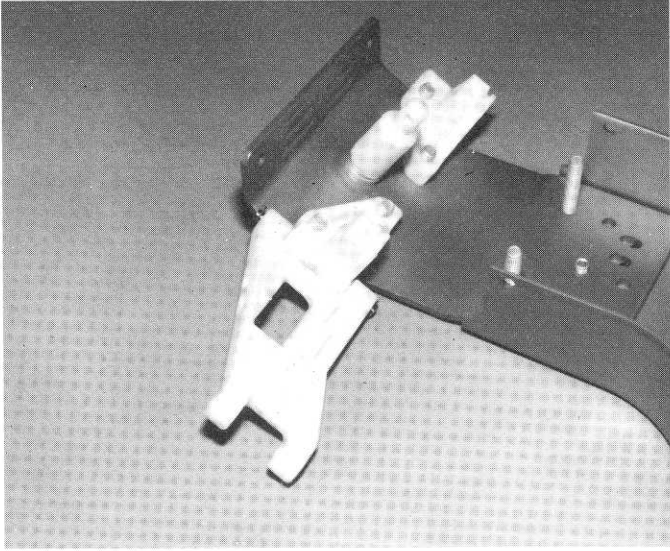

Fig. 8

□ **Fig. 10** Screw the short ball end #6270 into the #6217 steering block and secure it with the nut as shown. Assemble the right hand side, which will be inserted into the opposite side shown in fig. 10.

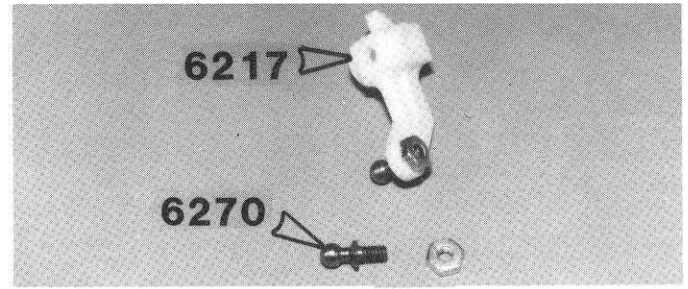

Fig. 10

□ **Fig. 9** From Bag #6-14 screw the long ball end #6273 into the left hand front block carrier #6213 as shown, then screw on the locking nut. Assemble the right hand parts.

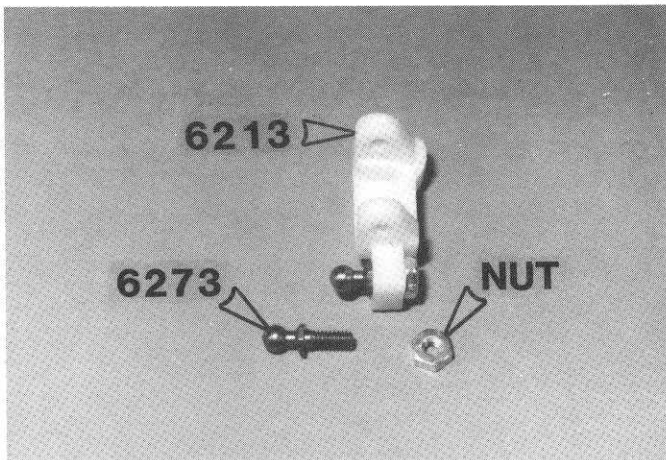

Fig. 9

□ **Fig. 11** Push the front axle #6218 into the steering block #6217 as shown so the hole in the axle lines up with the hole in the steering block. It may push together with your fingers. If not, LIGHTLY tap it into the hole. Assemble the right hand side in the same way.

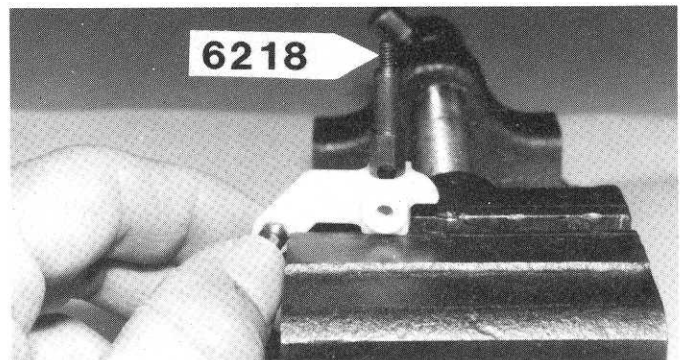

Fig. 11

□ **Fig. 11a** You'll notice that the hex part of the axle does not go all the way into the steering block. That's O.K. Just make sure the hole in the axle is lined up with the hole in the steering block.

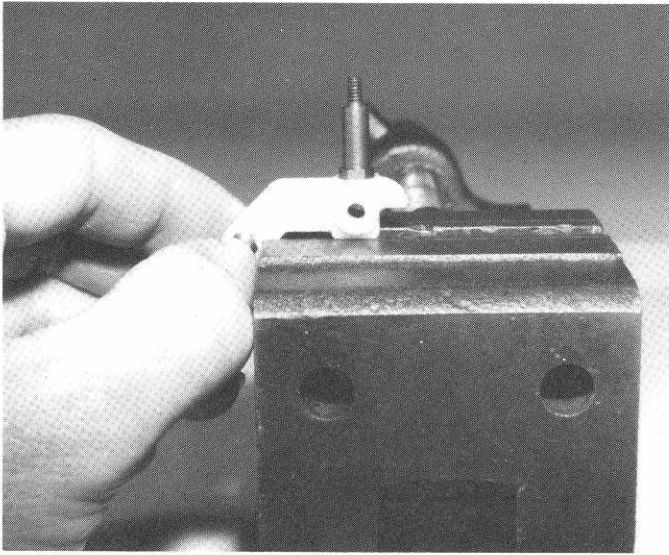

Fig. 11a

□ **Figs. 12 & 12a** Line up the steering block in the block carrier, as shown, and push the #6223 king pin through. Now, install "E" clips on the top and bottom ends of the pin. If you run out of "E" clips, there are extras in the shock bags. Install the R.H. steering block.

The pin will be loose in the block carrier but will be snug in the steering block, so you might have to lightly tap it in.

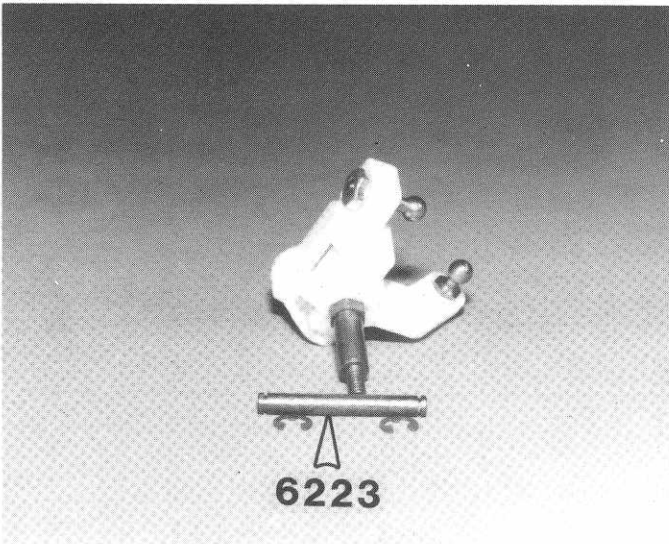

Fig. 12

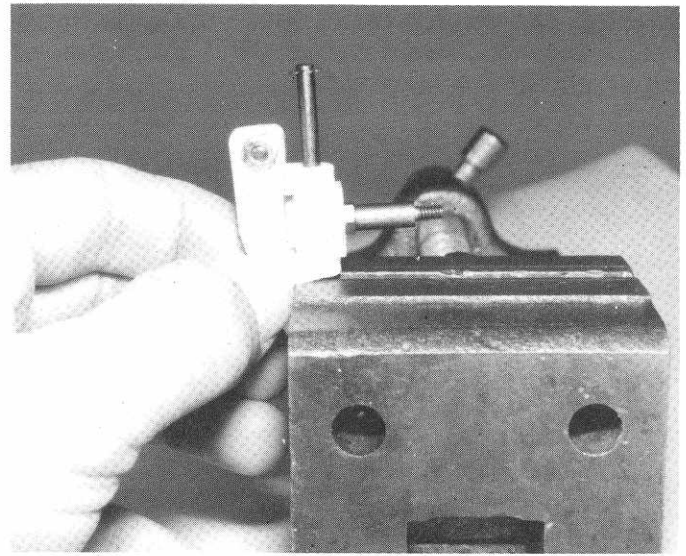

Fig. 12a

□ **Figs. 13 & 13a** Line up the holes in the block carrier with the holes in the A-arm and push the #6227 outer pin into the arm. Install the "E" clips. Do the R.H. side.

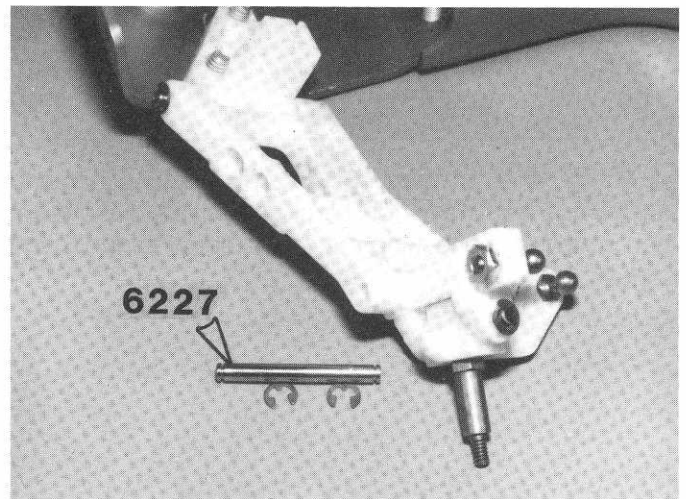

Fig. 13

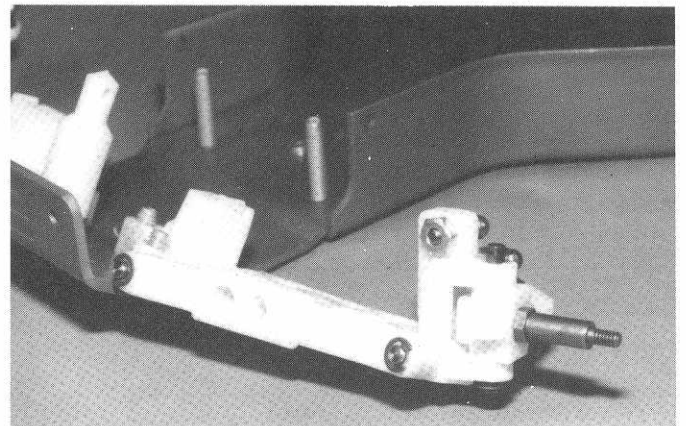

Fig. 13a

□ **Fig. 14** Take the #6231 front shock strut out of the same bag. In Bag #6-10 take out 2 of the 4/40 screws and install them in the shock strut in the locations shown.

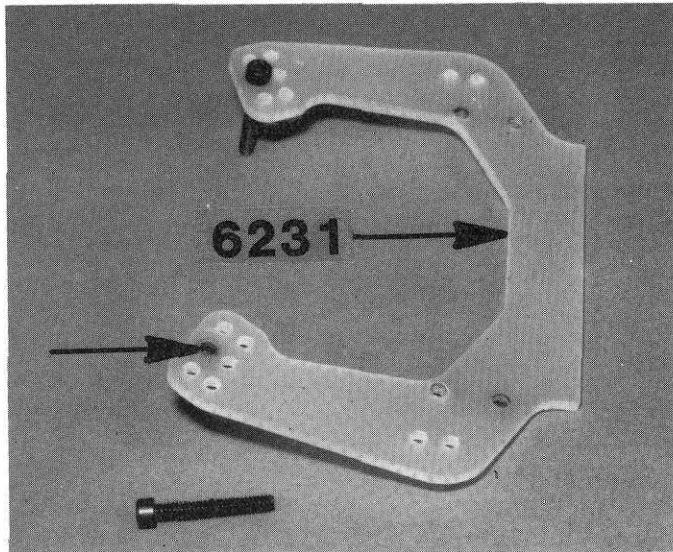

Fig. 14

□ **Fig. 15** From Bag 6-1 take the 2 short 4/40 screws and install the shock strut onto the 2 front suspension mounts. If the holes don't line up, loosen the aluminum screws in the chassis, align the parts and tighten all the screws.

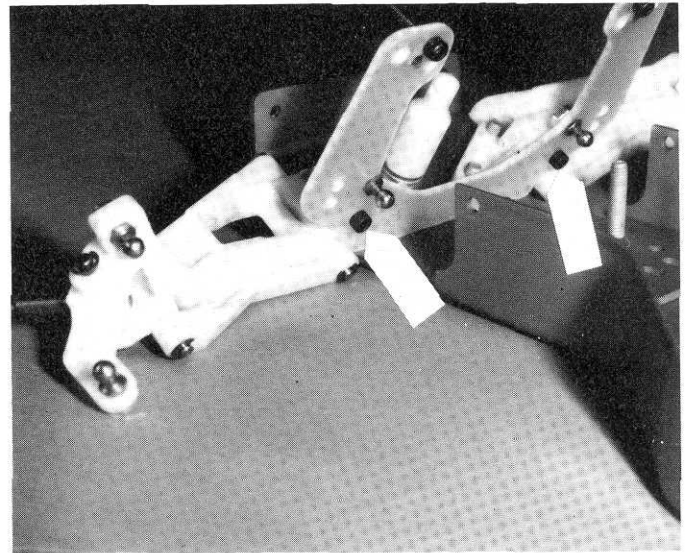

Fig. 15

□ **Fig. 14a** Take 2 of the short #6270 ball ends and install them in the shock strut in the locations shown. Then install the 2 nuts on the other side.

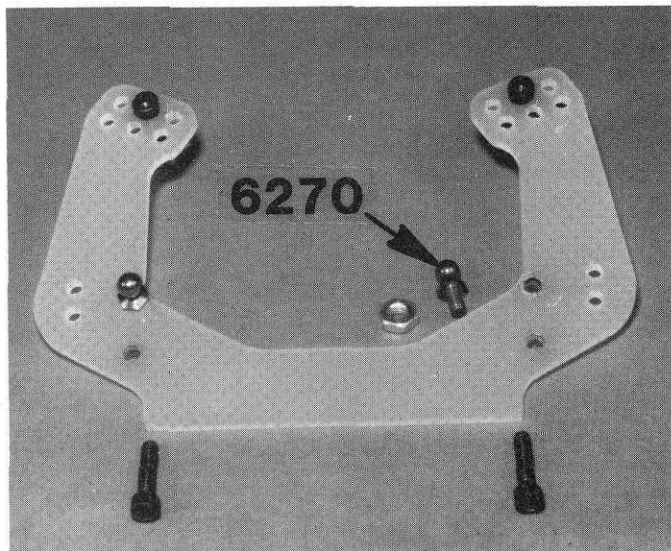

Fig. 14a

□ **Fig. 16** In Bag #6-1 take out the 2 #6259 threaded turnbuckles, and from bag #6-14 take out the #6374 plastic ball rod ends, as shown. Twist the rod ends and take 4 of them off.

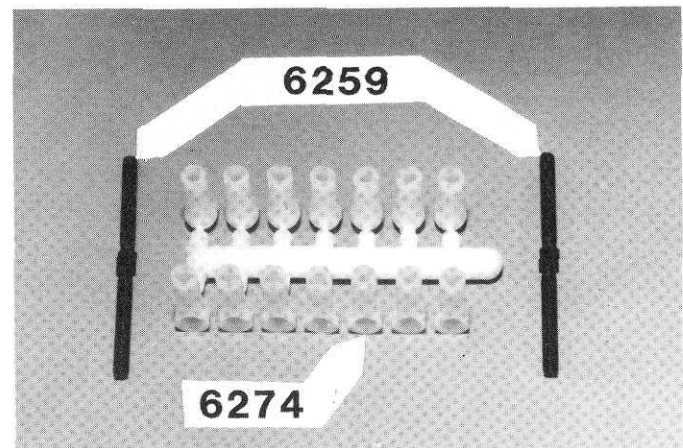

Fig. 16

□ **Fig. 17** Screw the plastic ball rod ends onto the rods, as shown. The rods have a LH thread on one end and a RH thread on the other end, so they will screw on in different directions. Screw them on evenly to the dimension shown, which is measured from the center of the ball cup.

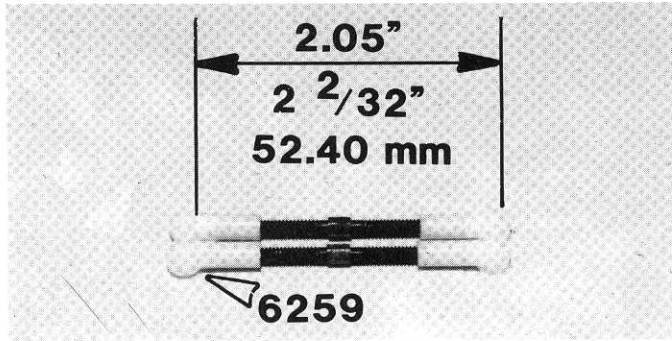

Fig. 17

□ **Fig. 18a** The rod ends can be removed quite easily from the balls by holding the rod end with a pliers, as shown, and twisting the rod end off the ball, as shown.

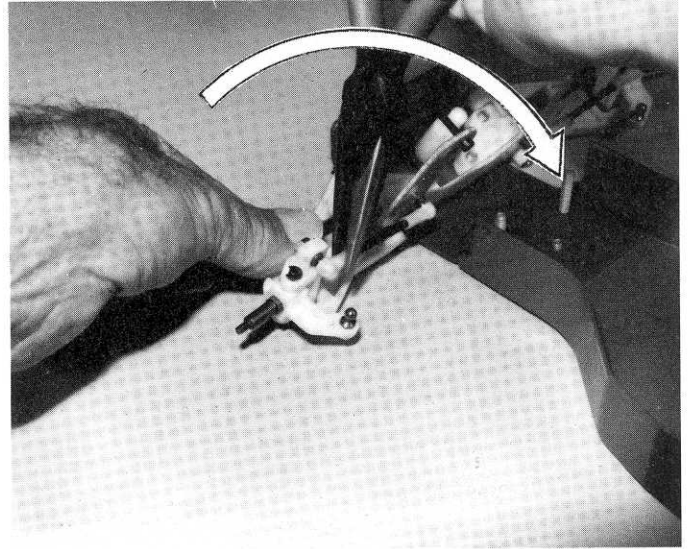

Fig. 18a

□ **Fig. 18** Snap the rods on the metal balls, as shown. You'll probably have to use pliers. Do the R.H. side.

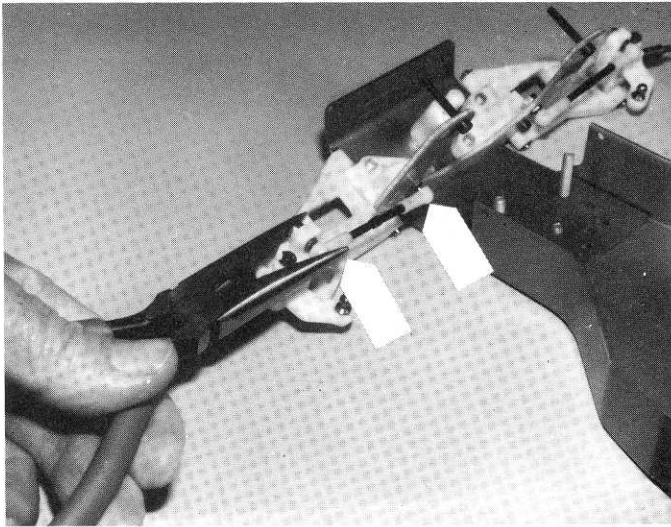

Fig. 18

□ **Fig. 19** In Bag #6-2, take the #6255 servo saver parts, and install the 4 short ball ends, as shown.

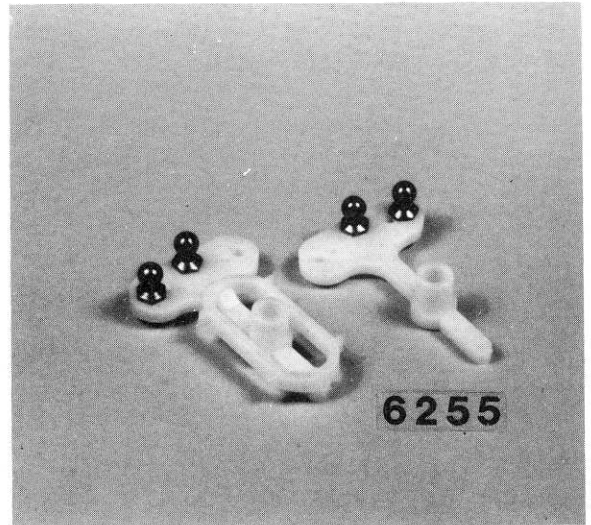

Fig. 19

- Fig. 20** Locate the servo saver arm...
- Fig. 21** and install it to the servo saver, as shown.

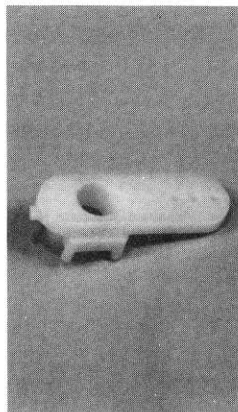

Fig. 20

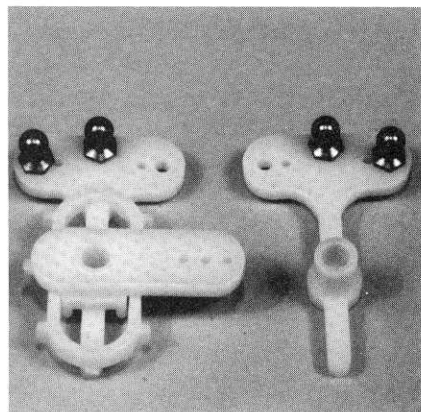

Fig. 21

- Fig. 22** Take the 2 thick washers out of the same bag, and put them on the 2 screws, as shown.

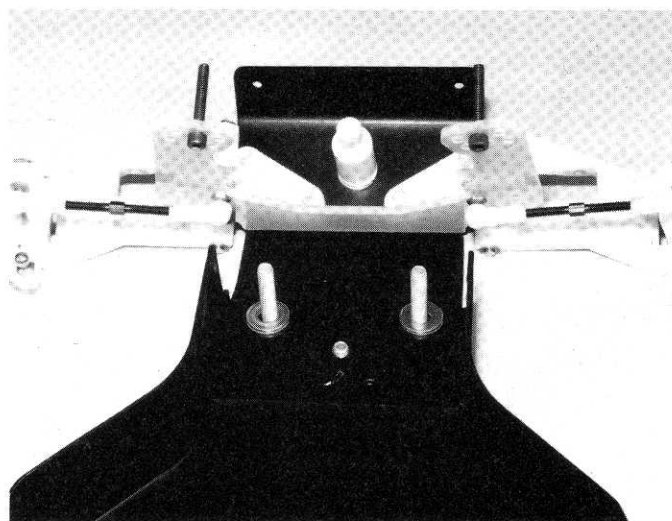

Fig. 22

- Fig. 23** Take the two long and one short turnbuckles and screw on the six plastic ball cups to the lengths shown.

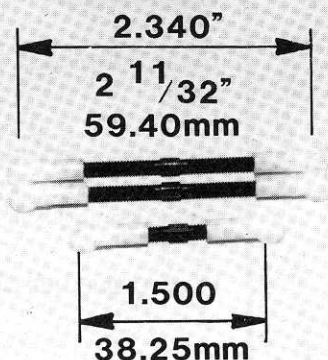

Fig. 23

- Fig. 24** Take the short rod and pop it on the servo saver with a pliers, as shown.

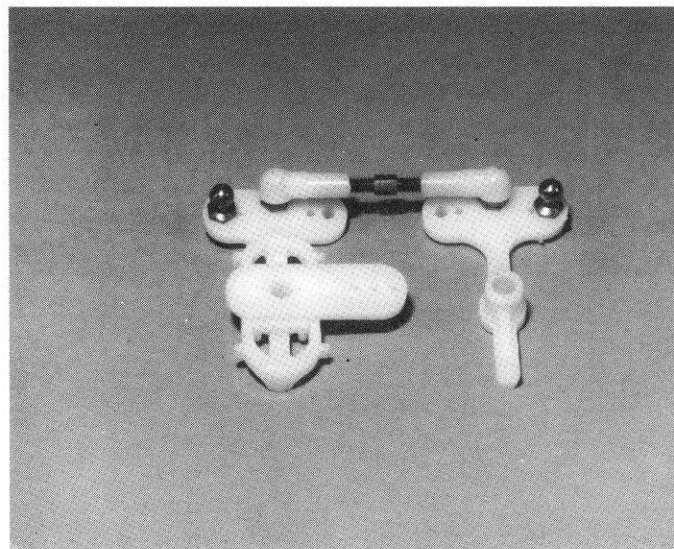

Fig. 24

- Fig. 25** Place the servo saver onto the 2 screws, as shown. Take the 2 nylon nuts and screw them down until the servo saver starts to tighten, then back the nuts off about 1/2 turn until the servo saver arms pivot freely.

Note: Team drivers will put a couple of small tie-wraps around the flex arms on the servo saver to pick up additional steering. CAUTION: This will also increase the load on the servo gears and possibly strip gears.

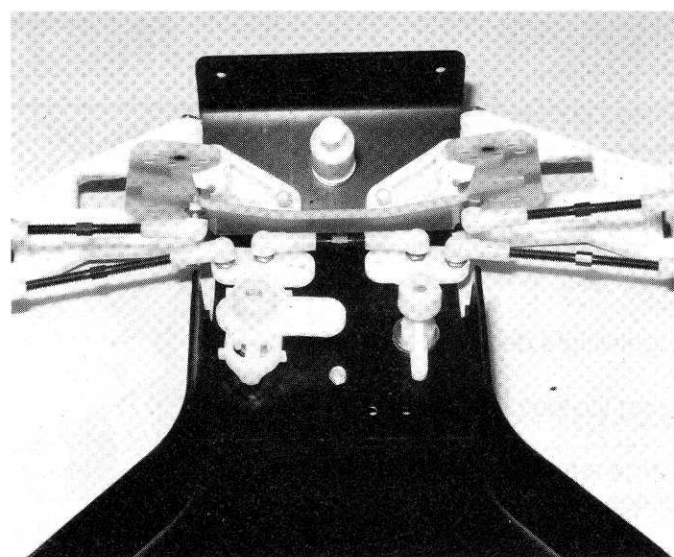

Fig. 25

□ **Fig. 26** Snap the L.H. and R.H. tie rods on, as shown.

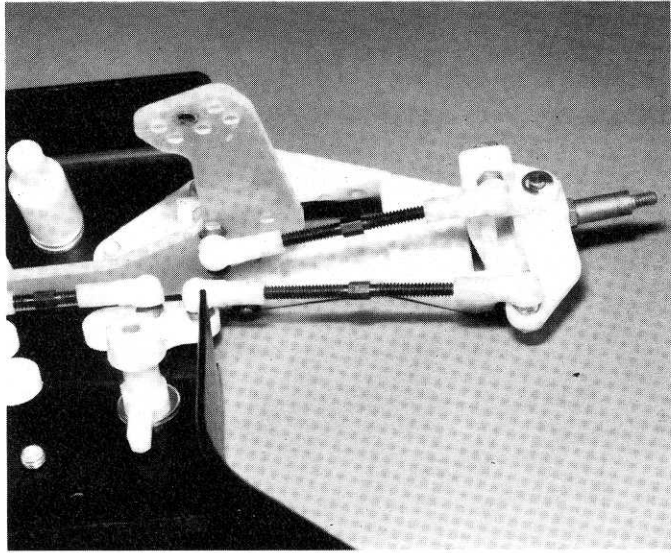

Fig. 26

TEAM ASSOCIATED
STEALTH
A T C TRANSMISSION

Transmission
for the **RC10**

INSTRUCTIONS

Featuring:

- Quick-change spur gear
- Case-to-motor plate dirt-proof seal
- Lightweight design
- Long-life clutch friction plate
- Large area/high torque clutch plates
- Low inertia drive train

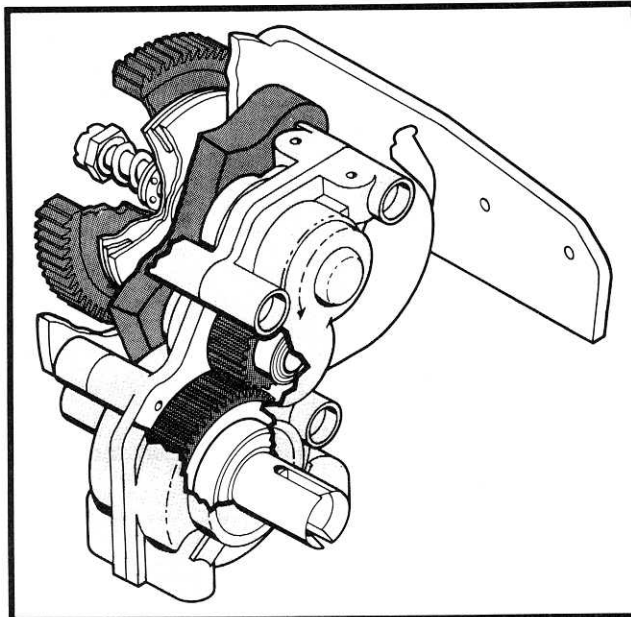

- Precision-molded 48 pitch gears with extra low 2.25 final drive ratio
- Reversible motor mounting
- Gold anodized mounting plate
- Class 3 stainless steel ball bearings
- Tungsten carbide differential balls
- Teflon sealed ball bearings
- High torque ball differential

STEALTH TRANSMISSION

We feel this transmission is the best in the world. It has enabled Team Associated to finish 1st, 2nd and 3rd at the World Championships in Australia and 1st, 2nd and 3rd at the ROAR Nationals in Northern California with our RC10 car. With this transmission your RC10 will be much easier to drive, enabling you to cut your lap times by a considerable amount. But it all depends, of course, on how well you assemble and maintain your transmission. So take your time and do it to the best of your ability.

□ **Figs. 27 & 27a** We'll start with Bag A, the differential. Take out the #6580 diff gear and the bag with the 12 large #6581 carbide diff balls. These carbide diff balls are the best there is. They will outlast the diff washers at least 10 times. NEVER replace these balls with any other balls except our #6581 carbide diff balls.

Now take out the #6591 Stealth white silicone diff lube. Another word of caution. DO NOT substitute any other type of diff lube on the balls. It took us countless hours of testing to find the correct silicone diff lube to make the diff work correctly. Do yourself a favor: use what comes in this kit!

Trim any excess flash off the inside of the gear.

Fill the holes in the gear with the silicone diff lube and then push the 12 carbide balls into the holes. Wipe the excess lube back into the ball holes with your finger.

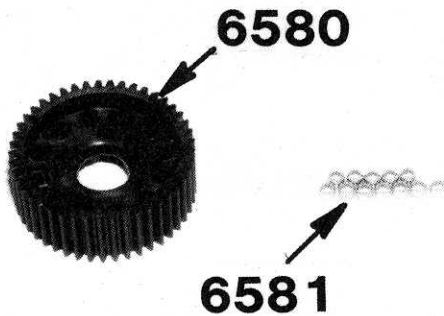

Fig. 27



Fig. 27a

□ **Fig. 28** Your gear.



Fig. 28

□ **Fig. 29** Clean all the silicone grease off your hands and push one of the #6589 ball bearings into the center of the gear. **CAUTION:** there are three bearings that have the same diameter, but different hole sizes. Make sure you use the #6589 bearing that fits onto the left hand hub, as shown.

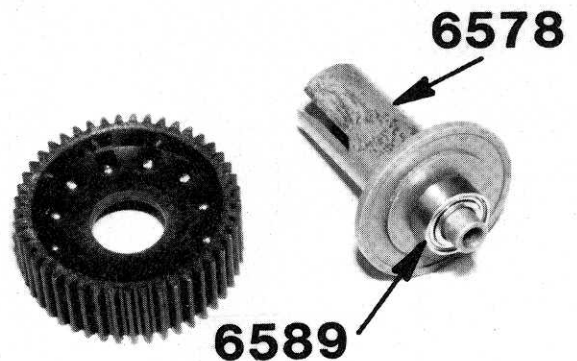

Fig. 29

Fig. 30 Your completed gear.

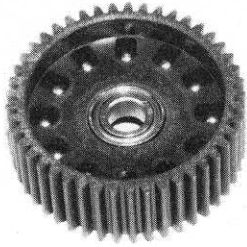

Fig. 30

Fig. 33 Take an Exacto knife and trim off any of the plastic T-nut that extends outside of the slot, as shown.

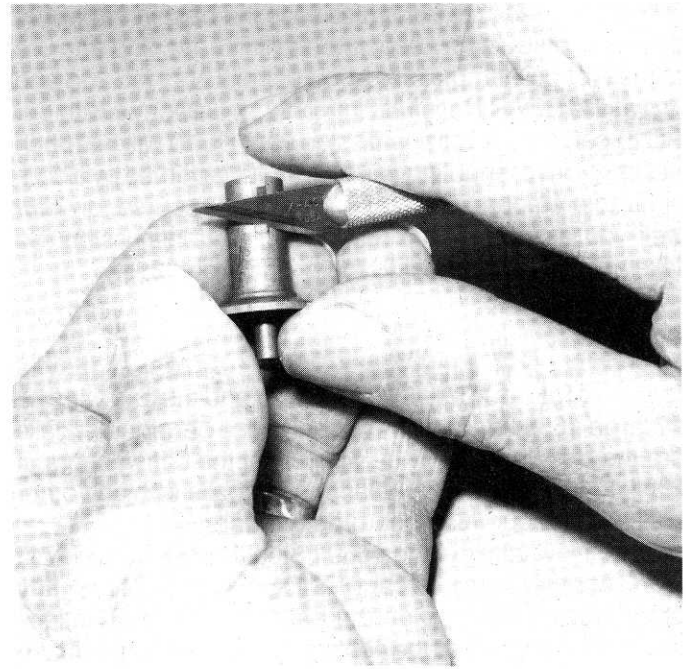

Fig. 33

Figs. 31 & 32 Take out the #6578 left hand diff outrdrive hub and **make sure it's clean and free from all burrs**. Push the #6582 diff thrust spring into the hub and then align the plastic T-nut with the slots in the hub and push the T-nut all the way in against the spring.

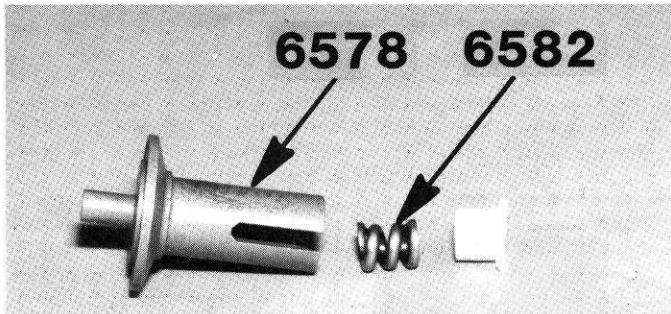

Fig. 31

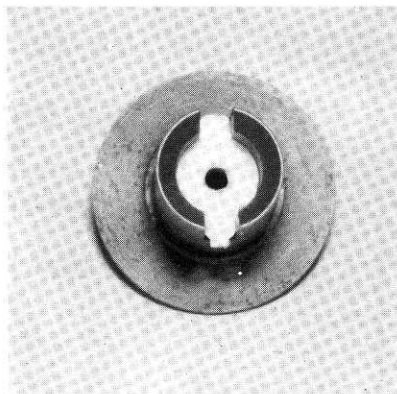

Fig. 32

Fig. 34 There should now be approximately a $3/32$ " or $.100$ " gap where shown.

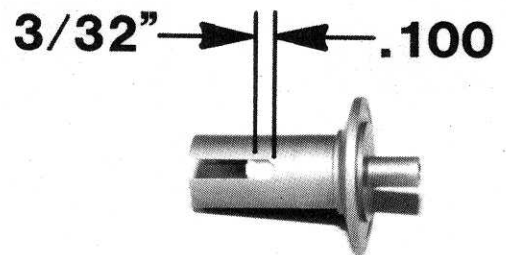

Fig. 34

□ **Fig. 35** Take out the #6575 diff thrust bolt, the two #6573 diff thrust washers and the #6576 carbide thrust balls.

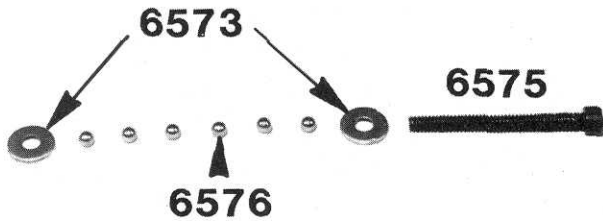

Fig. 35

□ **Figs. 36 & 37** Slip the two washers on the bolt, as shown, and then fill the area between them with the #6588 black grease. DO NOT use the black grease on the diff balls in the gear.

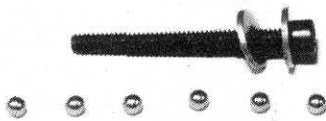

Fig. 36



Fig. 37

□ **Fig. 38** Now take the balls and place them all around the bolt between the two washers. The grease will hold them in place.

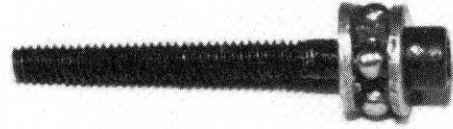

Fig. 38

□ **Fig. 39** Take the #6577 right hand diff outdrive hub, **make sure it's clean and free of all burrs**, and put one of the #6589 ball bearings into the hub. Now place one of the #6579 diff drive rings onto the hub. The ball bearings must go in with a simple push of your finger. **NEVER drive them in!**

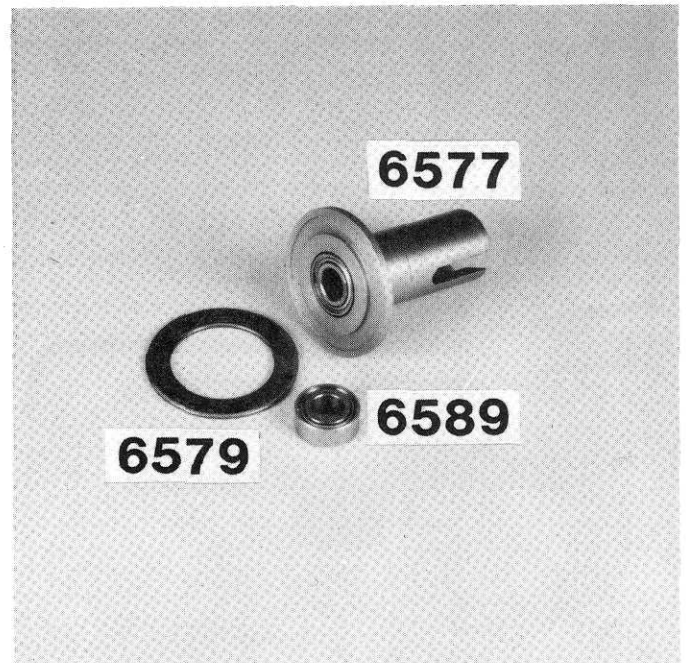

Fig. 39

Fig. 40 Your hub should look like this. DO NOT try to pin the drive ring to the hub. The hub is designed to lock the drive ring without pinning. Leave AS IS.



Fig. 40

Fig. 42 Turn the assembly upright. Make sure the drive ring is still ON and centered. Slip the diff gear onto the bolt as shown.

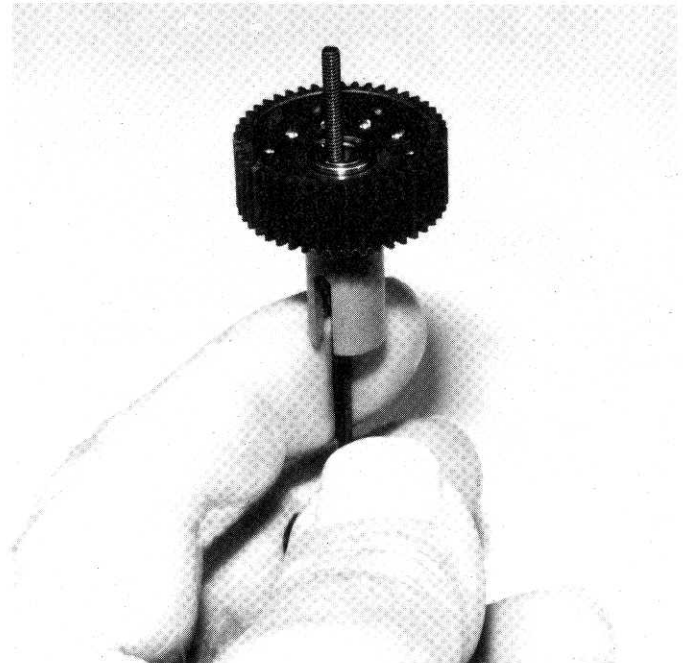

Fig. 42

Fig. 41 Slip the Allen wrench into the bolt head and then slip the assembly into and through the right hand hub.



Fig. 41

Fig. 43 Now place the other drive ring onto the diff balls and center it as close as possible to the gear.

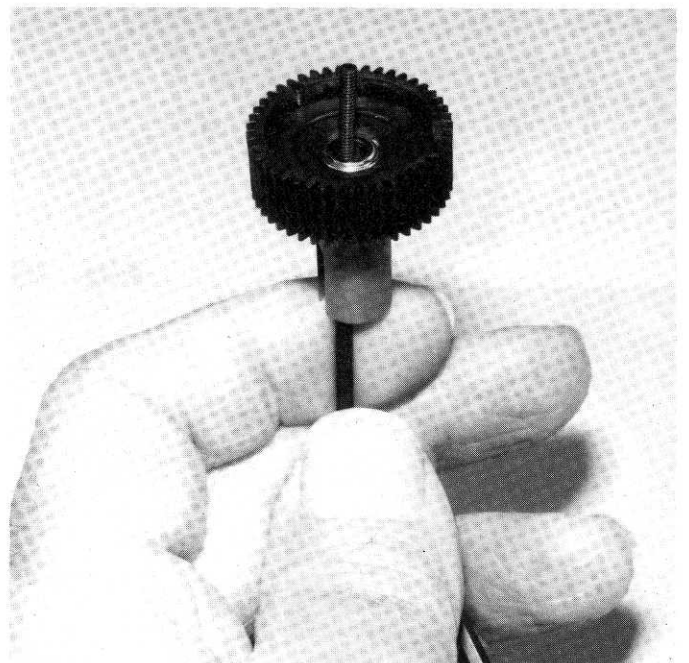

Fig. 43

□ **Figs. 44 & 45** Slip the left hand hub down onto the bolt, making sure the hub centers itself onto the drive rings. THIS IS IMPORTANT.

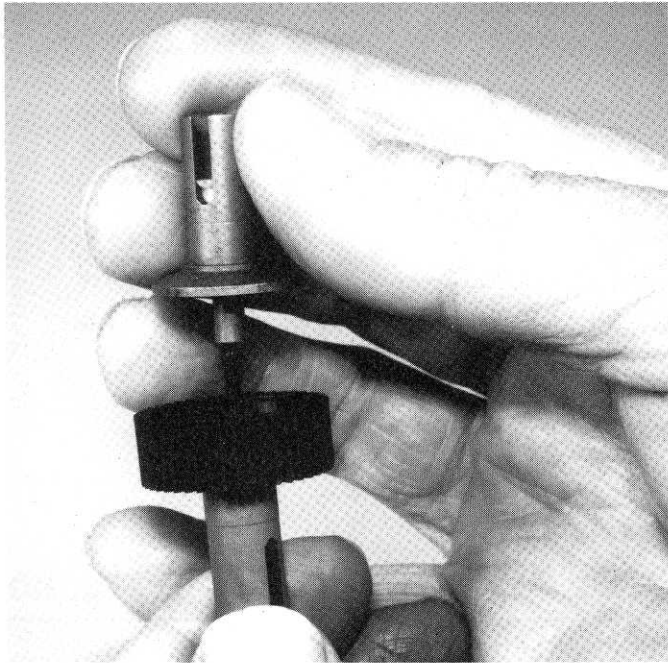

Fig. 44

□ **Fig. 45** Now start to tighten the bolt with the Allen wrench, making sure the hubs and drive rings stay centered. Do this very slowly. We want to make sure everything stays centered. We'll finish the tightening in the next step with figs. 46 & 47.

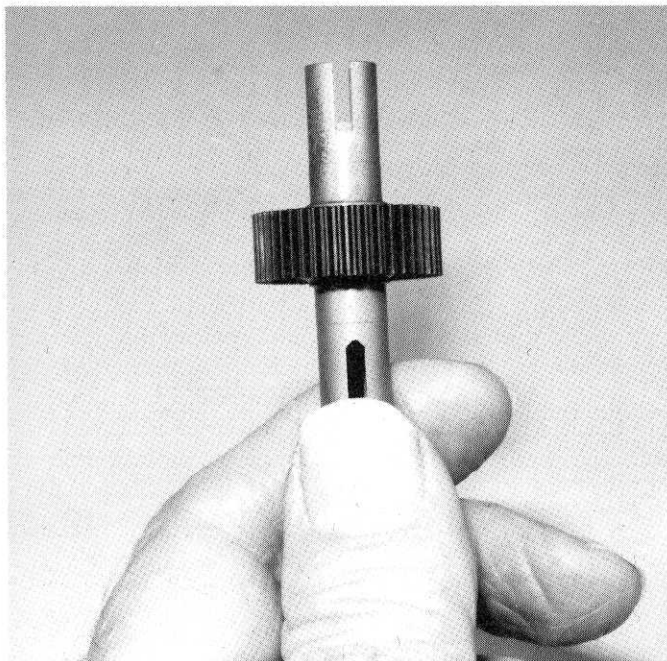

Fig. 45

□ **Figs. 46 & 47** Continue tightening slowly until the spring is just about completely collapsed. DON'T OVER-TIGHTEN! Correct adjustment is bottoming the spring and then backing off 1/8 to 1/4 turn.

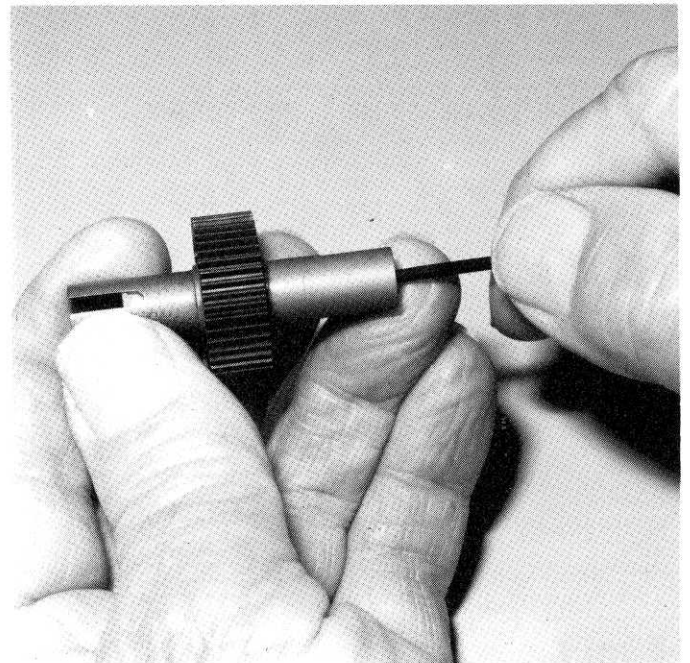

Fig. 46

□ **Fig. 47** As you're tightening, you'll notice the ear on the T-nut, shown by the arrow, moving closer and closer to the bottom of the slot in the hub. The spring should bottom out about the same time as the ear is at the bottom of the slot. When you feel the spring bottom out, that's when you back off 1/8 to 1/4 turn and your diff is correctly adjusted. The diff should operate very smoothly when turning the hubs in opposite directions. Recheck the adjustment before driving the car. There is never a need to adjust the diff in any other manner.

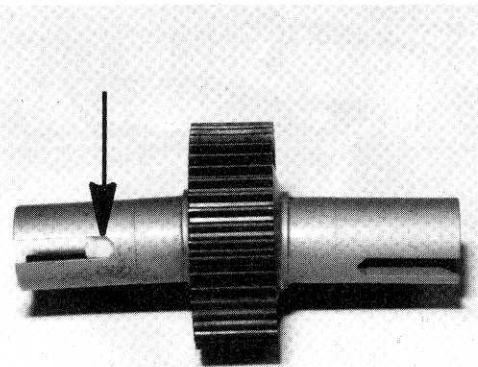

Fig. 47

□ **Fig. 48** Open Bag C and remove the #6565 left and right hand transmission cases (tranny cases), and remove any flash left from molding. Then install the #6906 upper and #6903 lower bearings.

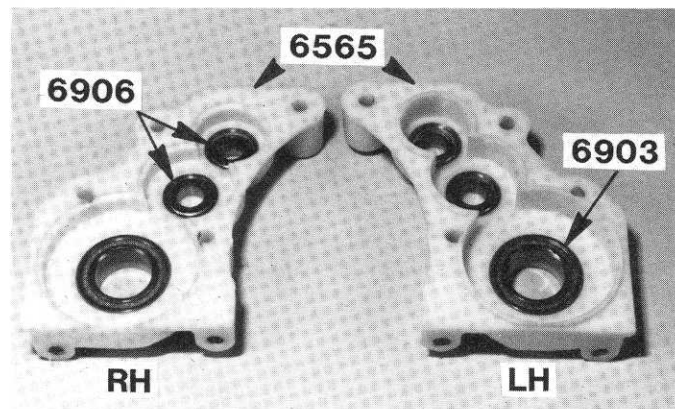

Fig. 48

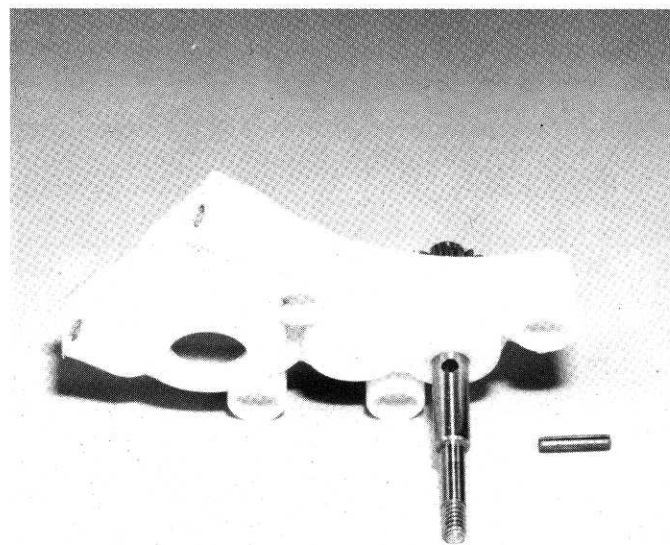

Fig. 50

□ **Figs. 49 & 50** Open Bag D and remove the #6571 drive gear assembly and slide it into the upper bearing in the right hand gear case.

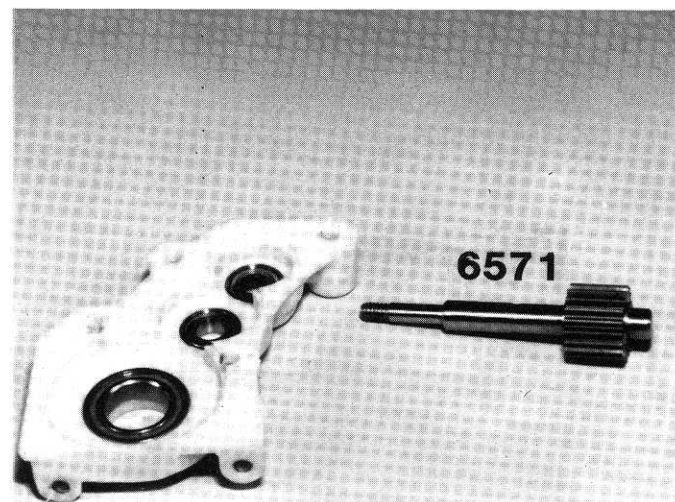

Fig. 49

□ **Fig. 51** Open Bag E and using a pliers, squeeze the roll pin into the hole in the shaft until it is equally spaced.

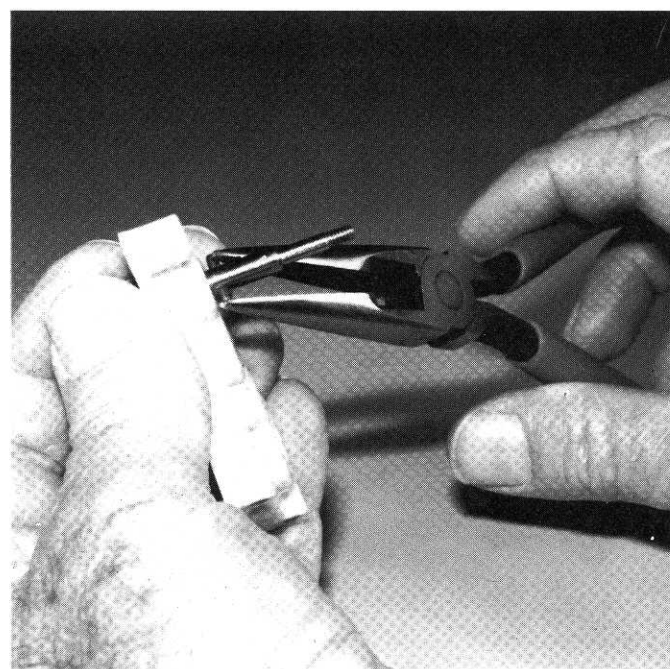

Fig. 51

□ **Figs. 52 & 53** Now take the diff assembly and slip the lower big bearing into the right hand case. Insert the right hand hub, which is the one that has the bolt HEAD in it.

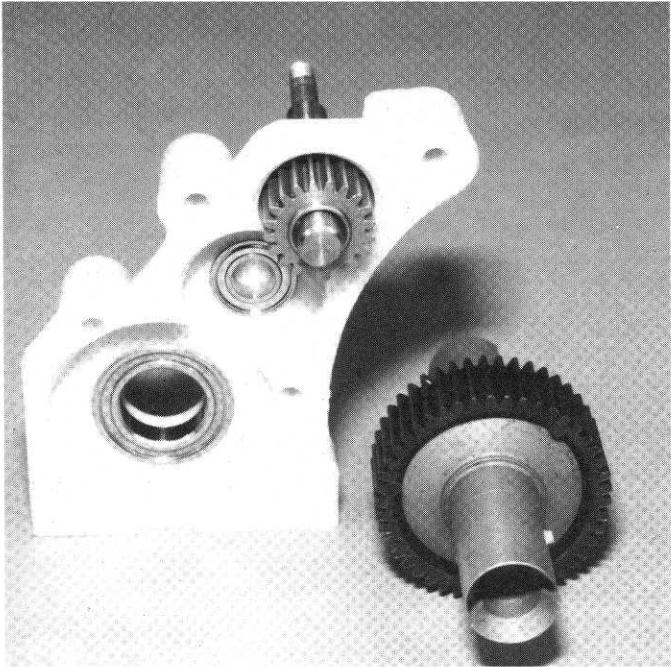

Fig. 52

□ **Fig. 54** Now carefully slip the #6570 idler gear into the center bearing.

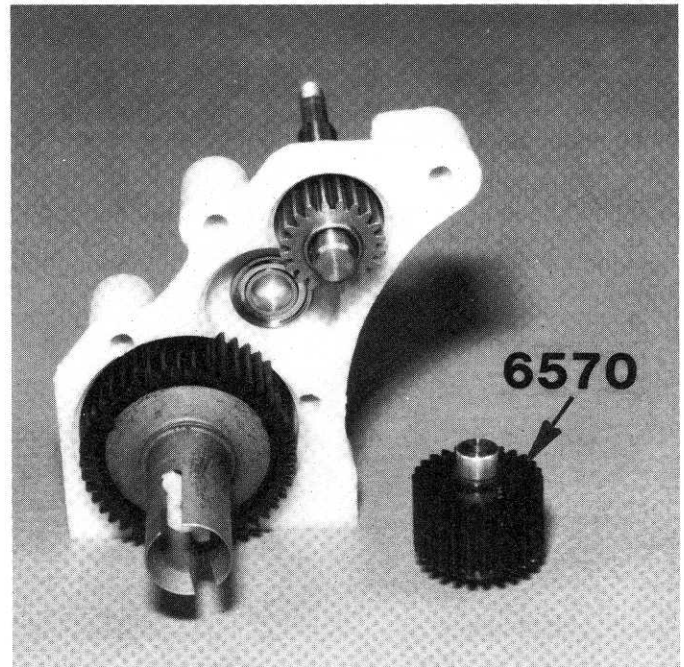

Fig. 54

□ **Fig. 55** The inside of your tranny should look like this. Slip the left hand side of your tranny onto the right hand side.

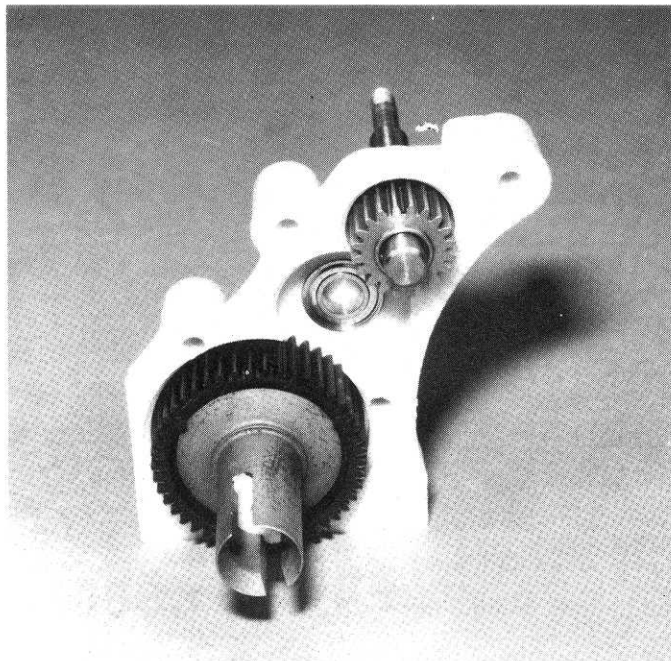

Fig. 53

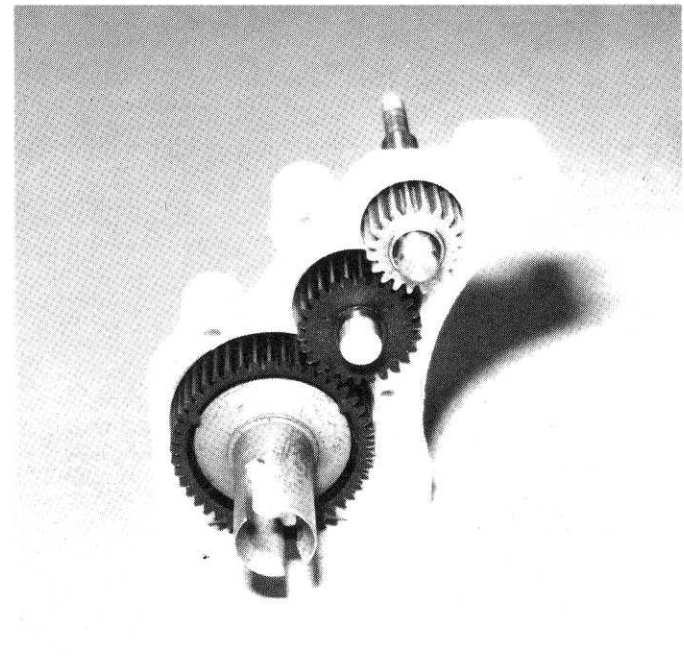

Fig. 55

Fig. 56 From Bag F put the four 1" Allen head case bolts into the case from the left hand side. You'll have to screw them in. Screw in the bolts so they extend about 1/8" on the other side.

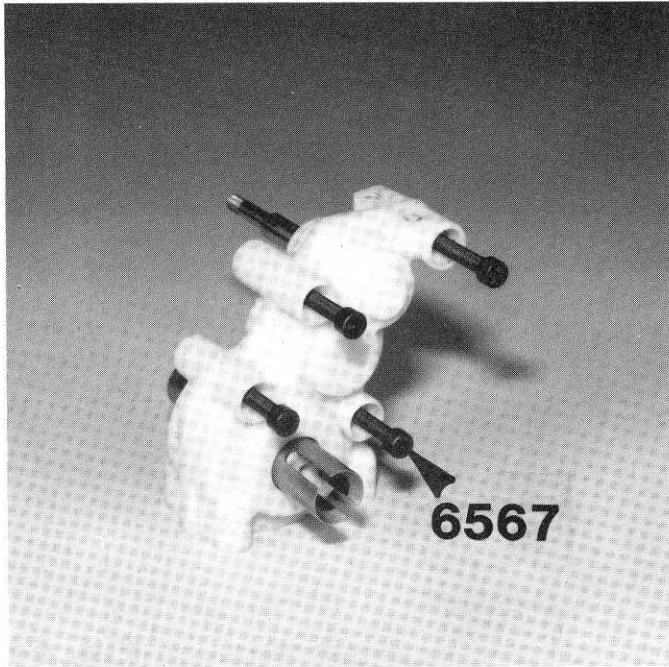

Fig. 56

Fig. 58 Slip the felt dust shield on the three bolts as shown and slip the fourth plastic spacer on the other bolt.

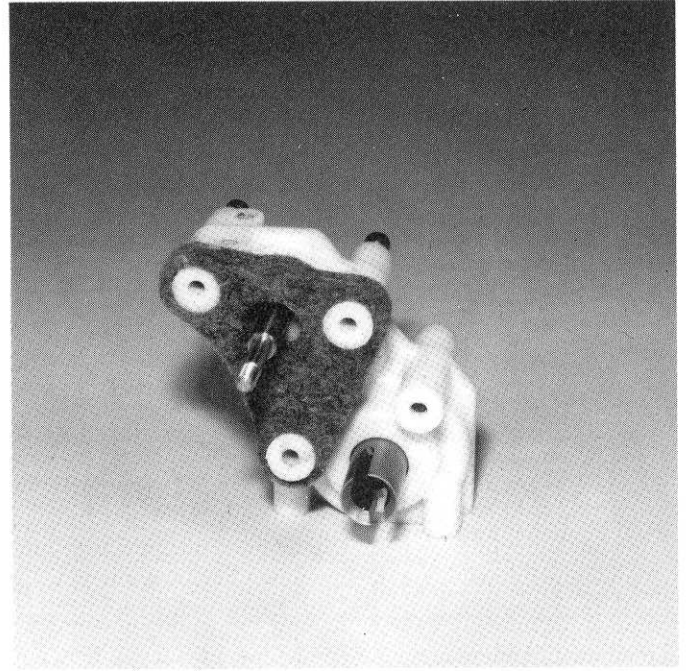

Fig. 58

Fig. 57 Now take the four #6569 plastic spacers and slip three of them into the #6566 felt dust shield so that the small end of the spacers can go into the case holes.

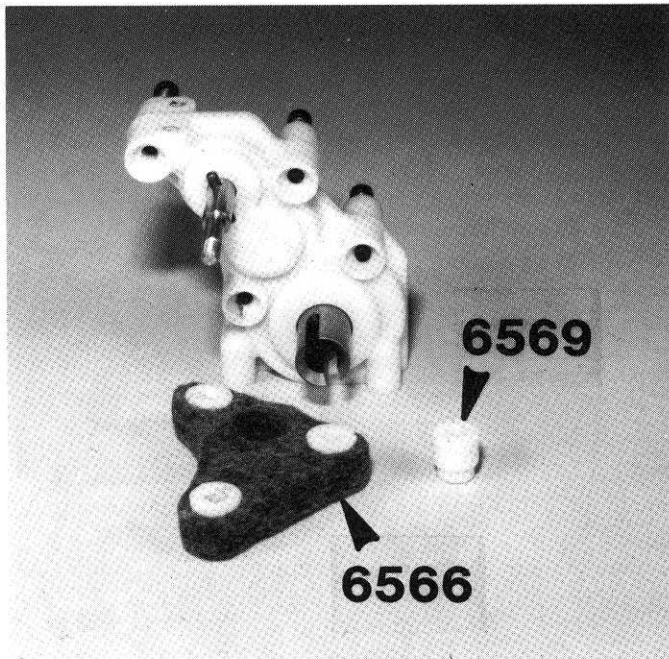

Fig. 57

Fig. 59 Now take the #6604 black motor mount and bolt the tranny to it in the location shown and tighten the four bolts. Then install the small plastic dust cap in the case, where the arrow indicates.

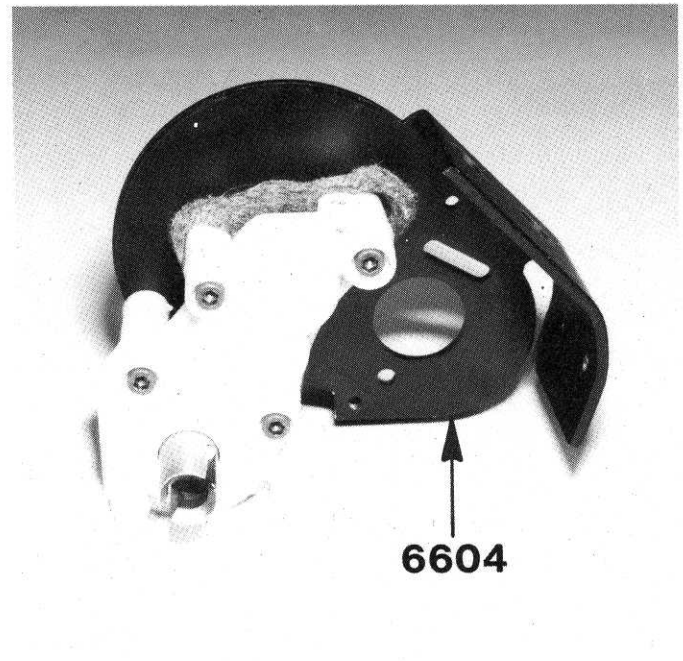

Fig. 59

□ **Figs. 60, 61 & 62** Now we'll assemble the clutch Torque Control assembly. Slip the #6583 clutch hub onto the shaft, making sure the slots align with the pin.

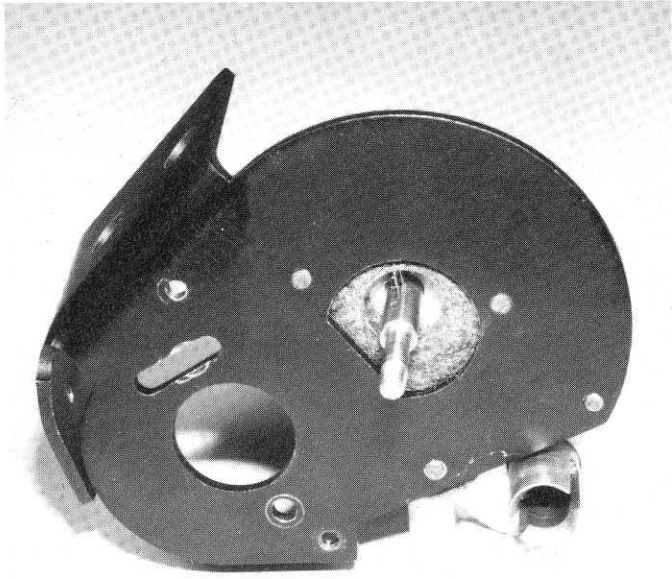

Fig. 60

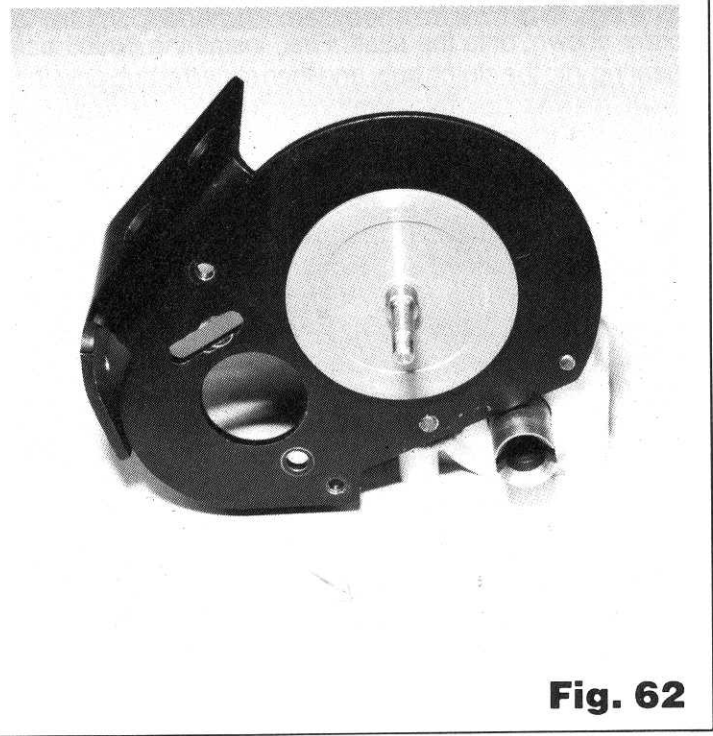
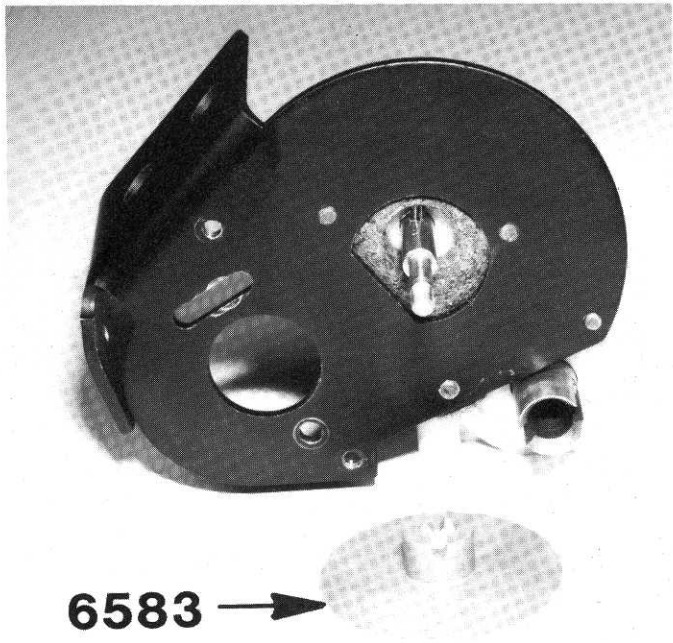

Fig. 62



6583 →

Fig. 61

□ **Figs. 63 & 64** Position the #6585 clutch disk so it's centered onto the #6584 outer hub, as shown.

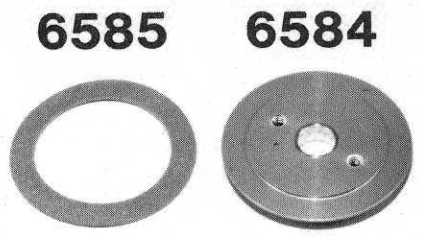

Fig. 63

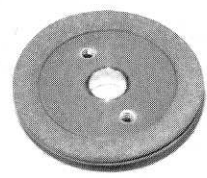

Fig. 64

□ **Fig. 65** Now we'll be assembling these parts, in the order shown, onto the shaft. First, install the #6906 ball bearing into the clutch hub, and then slide the hub onto the shaft, making sure the clutch disk stays centered on the hub.

Install one of the #6586 thrust washers, then the thrust bearing and the other thrust washer. (NOTE: when servicing this thrust bearing you can use a **very little** of the #6588 black grease.)

Now slip the #6587 spring on and start the nut on. Tighten the nut until about 1/2 thread is showing outside the nut. This is a good starting point for the clutch adjustment. If the ball bearing in the clutch hub will not slip onto the shaft, then you have not used the correct bearing described in fig. 29. Disassemble the diff and install the correct bearing.

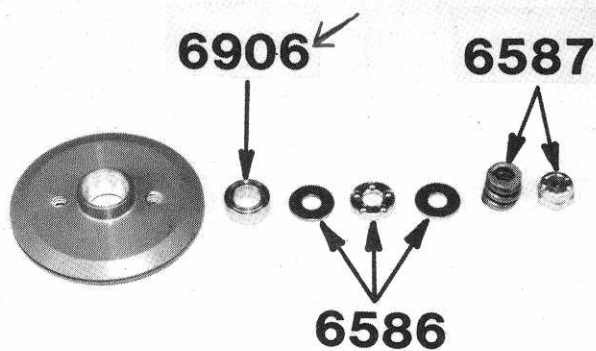

Fig. 65

□ **Figs. 66 & 67** Deburr the hole and mount the # 6693 81 tooth 48 pitch spur gear with the two #6568 mounting screws.

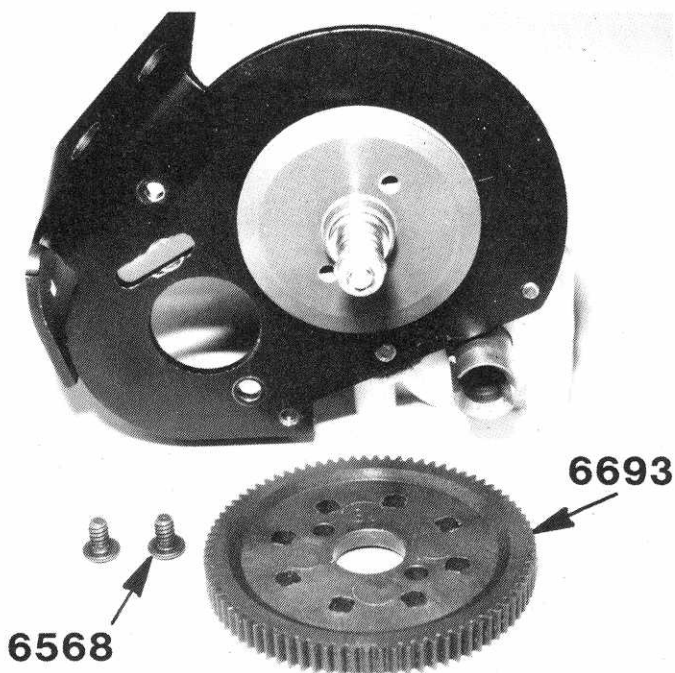

Fig. 66

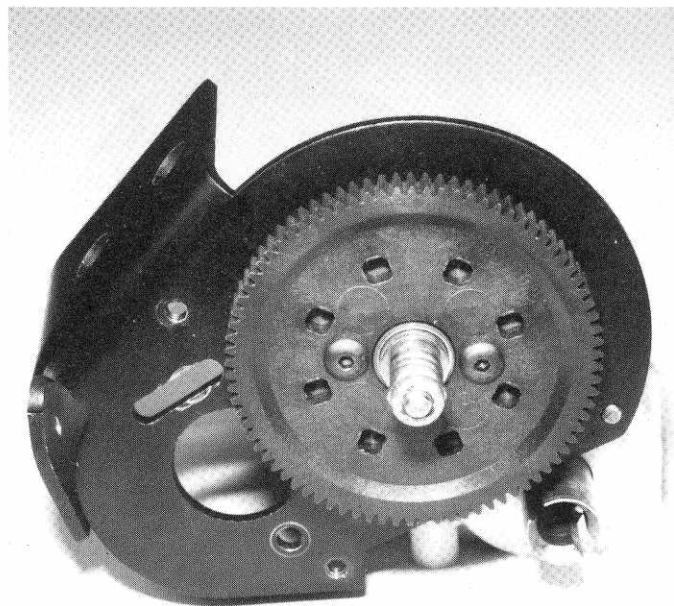

Fig. 67

□ **Fig. 68** Cut out the center button hole and then install the #6608 gear cover with the two Allen screws.

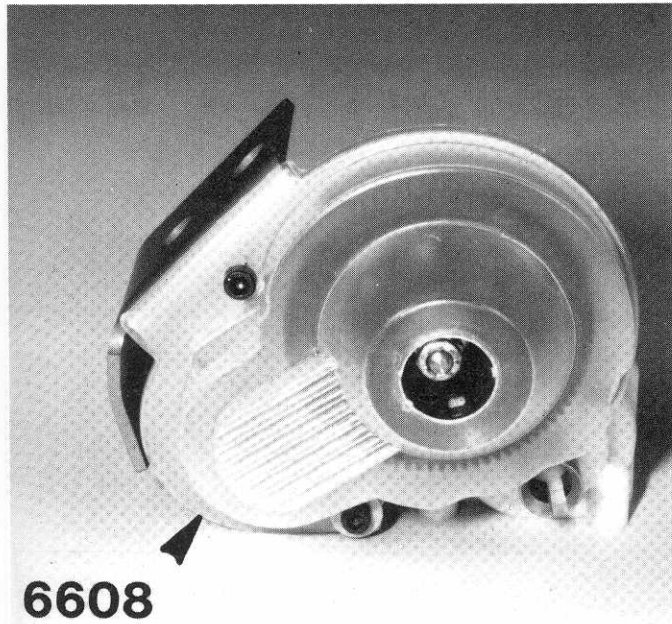

Fig. 68

□ **Fig. 70** Make sure you put the button back in to keep dirt out.

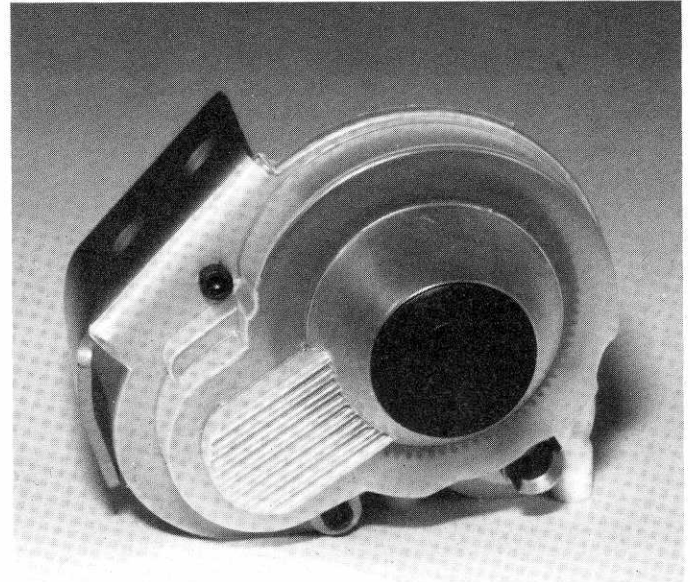

Fig. 70

□ **Fig. 69** You'll be able to make clutch adjustments quite easily right before the start of the race with a hex driver.



Fig. 69

CLIFF LETT SAYS: IMPORTANT-- PLEASE READ

DIFFERENTIAL ADJUSTMENT

Once the differential has been correctly adjusted there should be no need to change it until rebuilding time. **Be very careful when bottoming the spring during adjustment and extremely accurate when backing the screw out 1/8 to 1/4 turn. This is the most important adjustment in the transmission.** When you've made all of the necessary adjustments and the car is ready to run (battery and motor included), apply a small amount of throttle while holding one of the rear wheels stationary. Do this for about 15 seconds. This will correctly seat all of the differential parts. Now re-check the diff adjustment.

You should rebuild the differential when the action gets somewhat "gritty" feeling. Usually cleaning and applying new diff lube will bring it back to new condition. The tungsten carbide balls (which are standard parts) should very rarely need changing. However, the large and small thrust washers should be checked regularly.

TORQUE CLUTCH ADJUSTMENT

It is very easy to over-tighten the torque clutch. If you do, you may damage the differential. Therefore take your time and allow the clutch disk to properly seat before adjusting to race setting. This is done by running the torque clutch adjustment a little on the loose side for about one minute. Remember that the purpose of the clutch is to gain traction, not break the tires loose.

REAR END ASSEMBLY

□ **Fig. 71** From bag #6-4 take the #6323 rear bulkhead out, and the 2 #6327 wing tubes. The wing tubes are the short tubes. Take the tubes, round off the square cut corners on the ends with a file, and tap the wing tubes into the bulkhead.

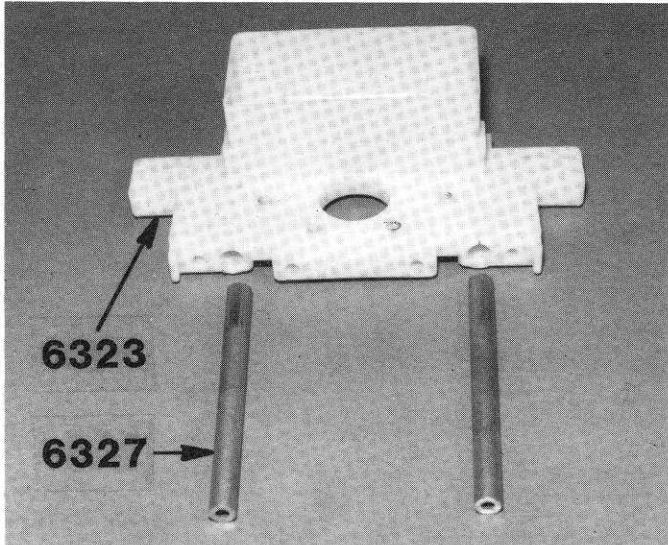

Fig. 71

□ **Fig. 72** Install two of the long ball ends in the bulkhead where shown.

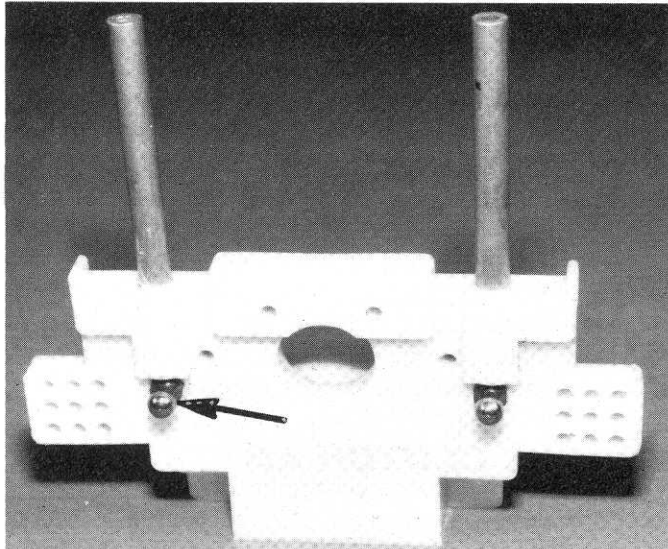

Fig. 72

□ **Fig. 73** Take the 2 Phillips screws and attach the bulkhead to the chassis, but DO NOT tighten the screws all the way down yet, but almost tight. Then install the two 4/40 Allen screws, as shown, but do not tighten these down yet. We'll be tightening these four screws down later.

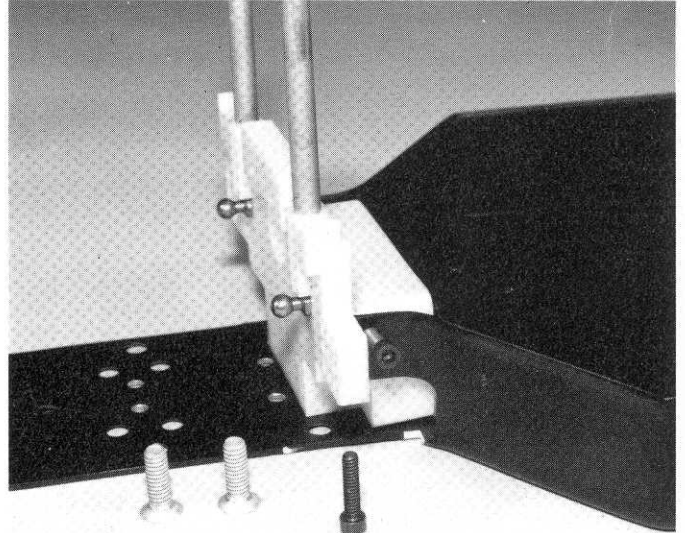

Fig. 73

□ **Fig. 74** Bulkhead installed.

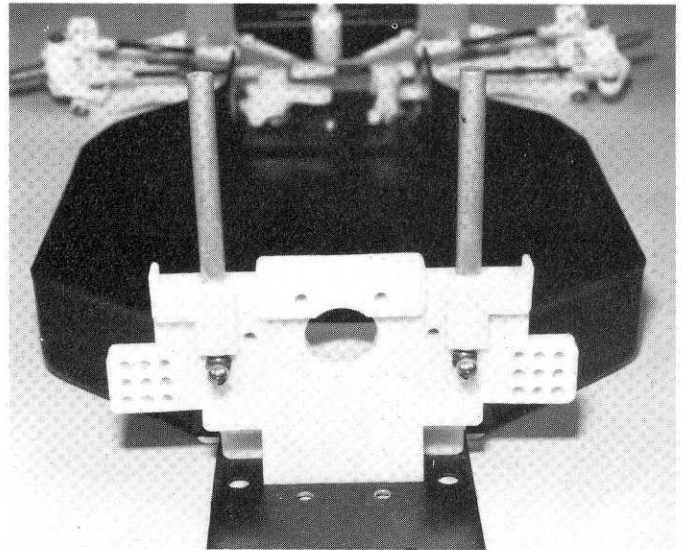

Fig. 74

Fig. 75 Take the transmission housing and install it with four 4-40 x 3/8 flathead socket screws. Do not tighten the screws all the way yet. Be sure the motor mount plate is INSIDE of the chassis at the back, as shown.

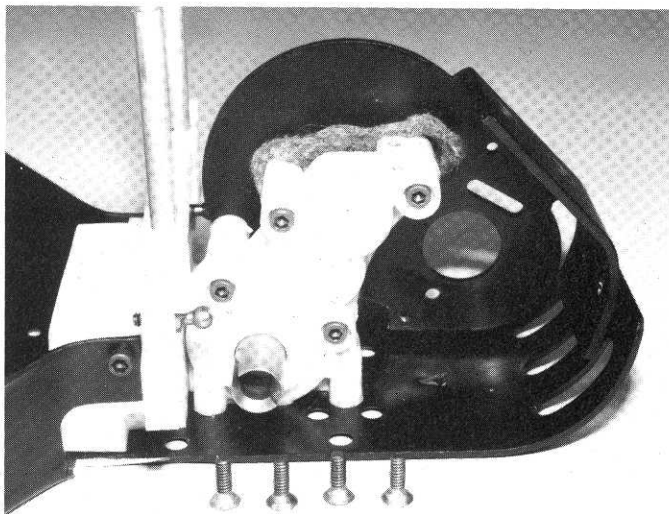

Fig. 75

Fig. 77 Take the #6325 transmission brace and install the rear body mount.

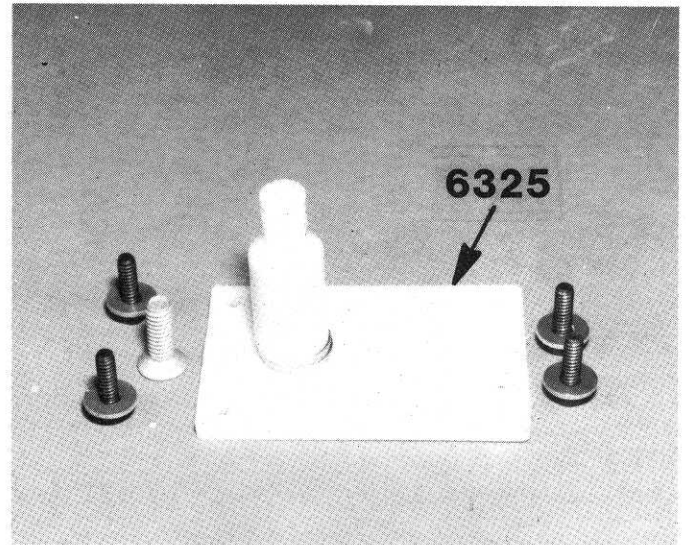

Fig. 77

Fig. 76 These 6 screws should be loose yet.

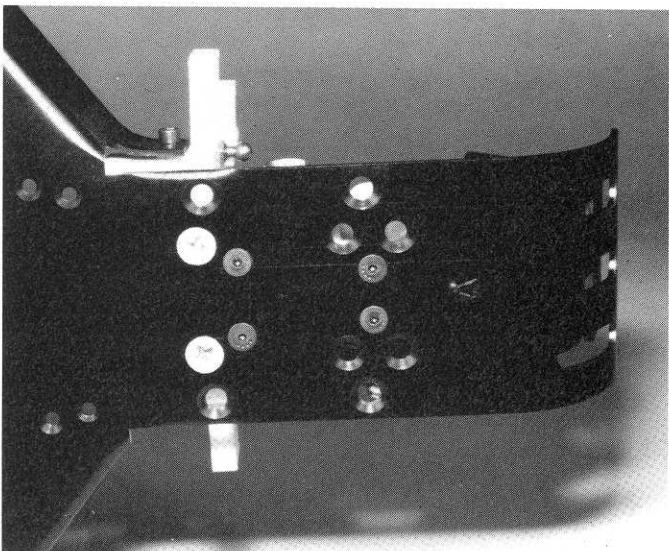

Fig. 76

Fig. 78 Install the transmission brace with 4 Allen screws and washers, as shown, but do not tighten all the way yet.

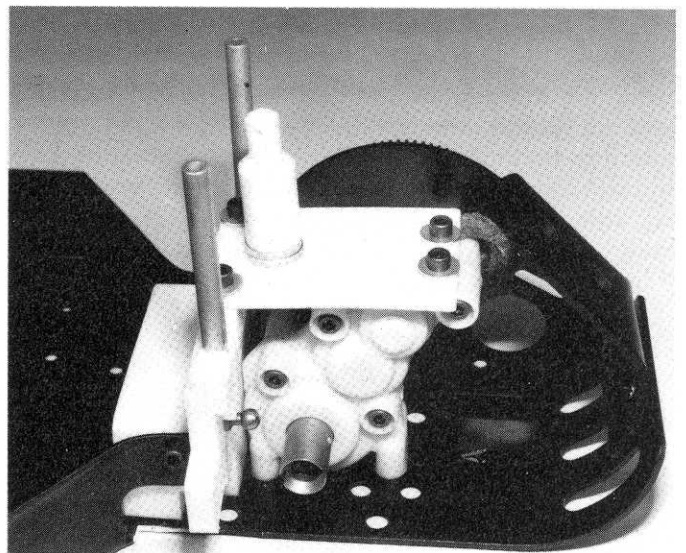

Fig. 78

□ **Fig. 79** Attach the rear of the chassis plate to the motor mount with 2 short Allen screws and tighten down. Now go back and tighten down all the screws in figs. #75-79. Be careful when tightening screws into plastic. As soon as they feel like they're starting to tighten up - stop - so you don't strip out the plastic.

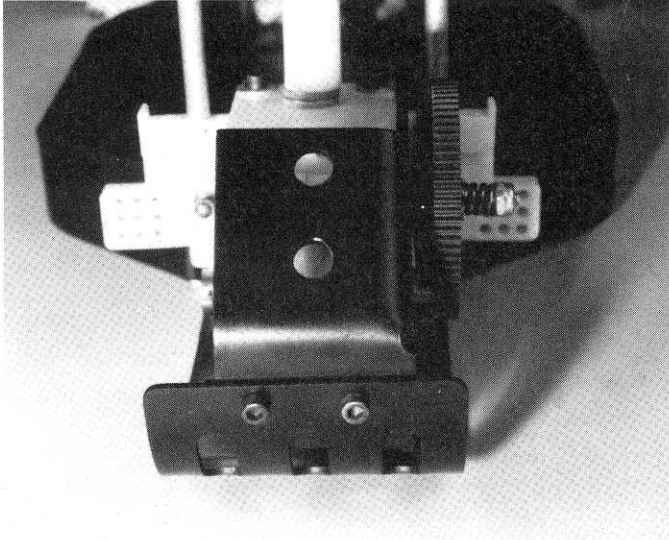

Fig. 79

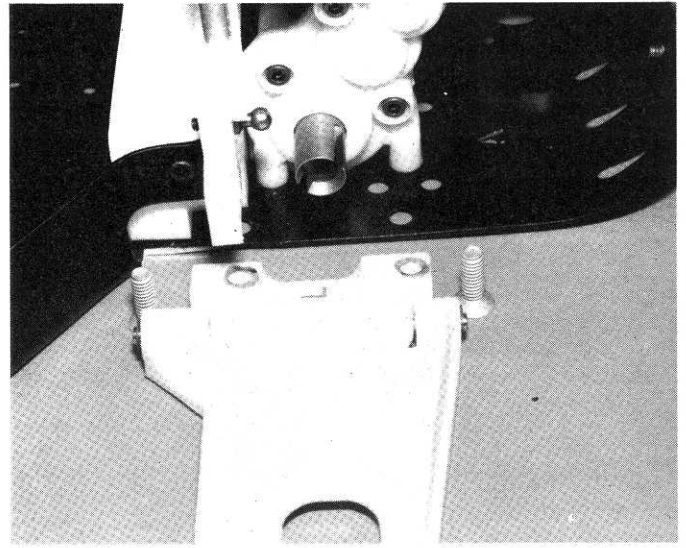

Fig. 81

□ **Figs. 80 & 81** Take the #6360 rear suspension mount, out of bag #6-8, with the letter "L" on the bottom, the #6355 L.H. rear "A" arm and the #6380 inner hinge pin. Line up the holes in the arm and mount and install the pin. Install the two "E" clips.

NOTE: The left and right rear mounts are attached together by a thin "runner" that should be removed with scissors.

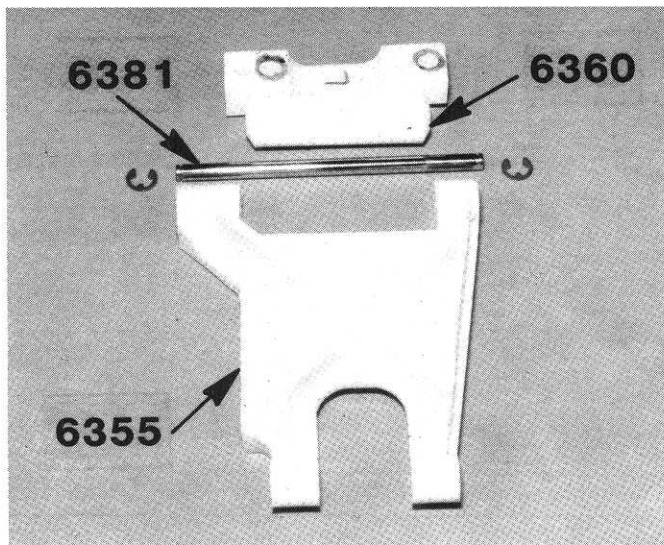

Fig. 80

□ **Fig. 82** Install the L.H. mount to the chassis with 2 Phillips screws as shown. Now, install the R.H. arm.

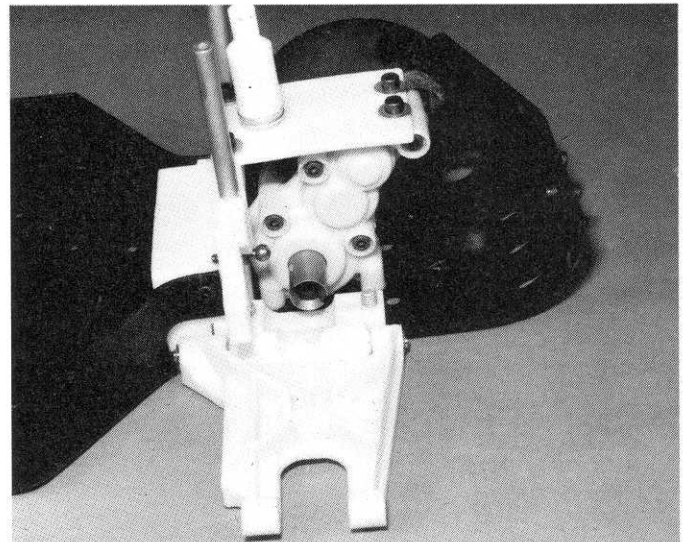

Fig. 82

□ **Figs. 83 & 84** Take the left hand hub carrier #6366, the one that has the letter "L" on it, and push the two ball bearings #897 in it.

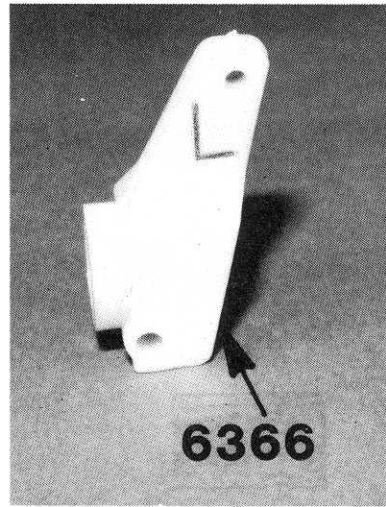

Fig. 83

□ **Fig. 84** Take the #6371 universal dogbone drive-shaft and slip three of the thin washers on it and then slip it into the hub carrier ball bearings. Add two more of the thin washers and then install the roll pin as shown in Fig. 85. If the washers make the fit too tight, remove one of the outside washers.

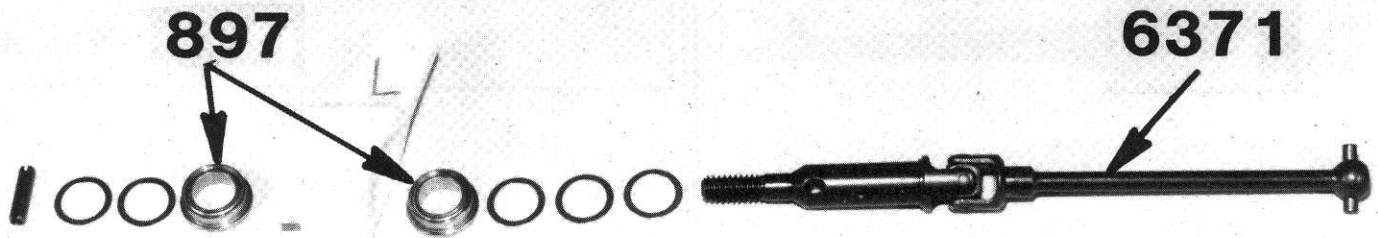

Fig. 84

□ **Figs. 85 & 85a** For this step you may need 3 hands, so get a friend to help you. Set the axle on a vise

or a flat surface. Hold the roll pin or slotted pin with a needle nose pliers and align the pin with the hole in the axle. Lightly tap the pin in the axle so it's evenly spaced.

An alternate method of installing the pin is shown in fig. 85a, using a pair of water pump pliers. Start the pin by holding with small pliers and pushing into the hole with a twisting motion. Finish with large pliers as shown. Angle the pliers slightly to allow the pin to come through the other side.

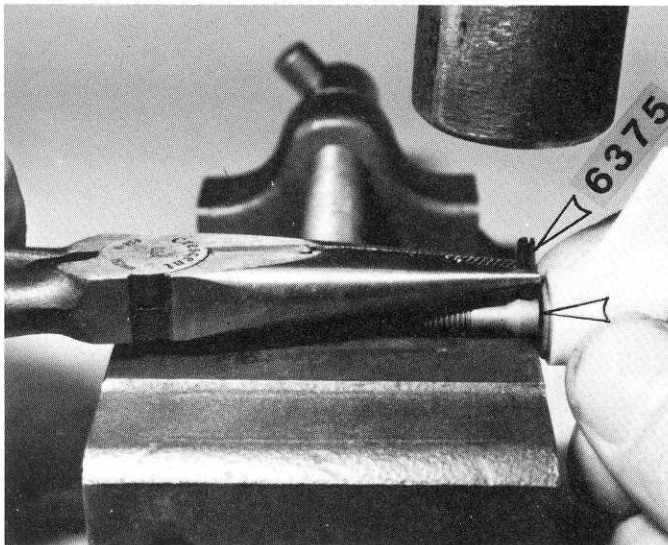

Fig. 85

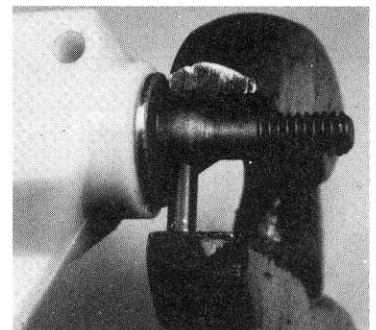

Fig. 85a

□ **Figs. 86, 86a & 86b** Install a ball end and nut as shown. Install the LH hub carrier in the LH "A" arm with the #6381 outer hinge pin. Install 2 "E" clips. Install a long ball end in the forward side of the hub carrier, as shown, and install the nut. Install the R.H. hub carrier.

NOTE: The pin is intentionally a tight fit in the hub carrier; do not ream the hole. The pin will turn in the A-arm.

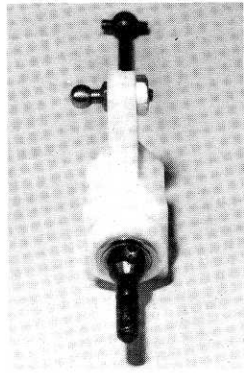

Fig. 86

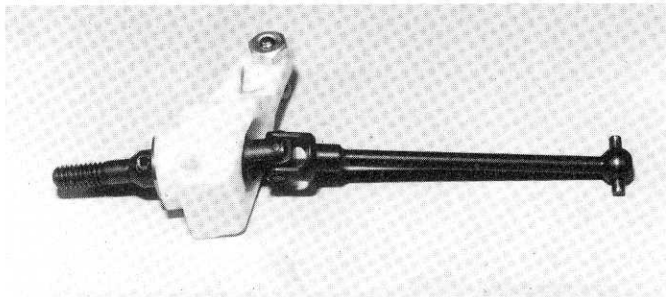

Fig. 86a

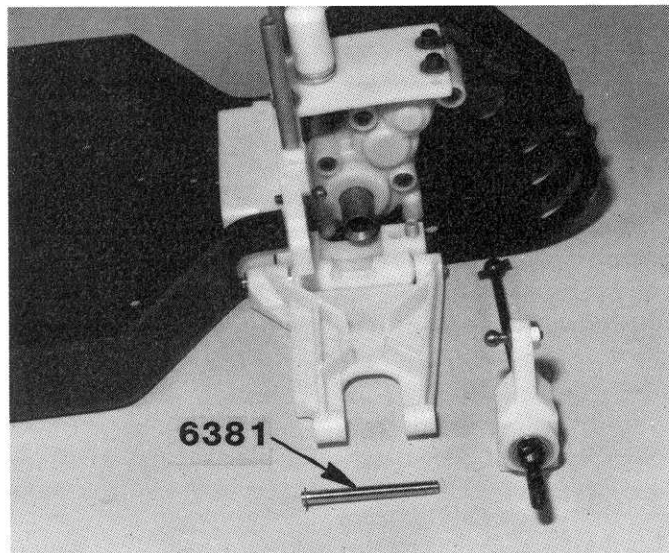

Fig. 86b

□ **Fig. 87** Your L.H. rear end should look like this now.

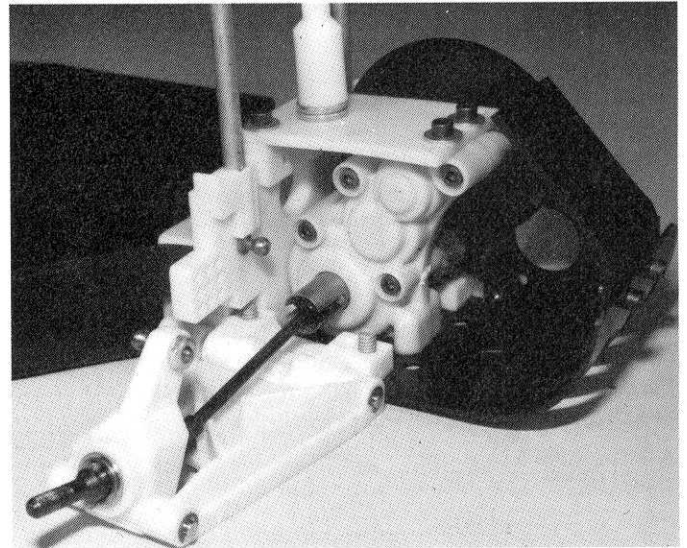

Fig. 87

□ **Fig. 88** Take the two #6262 threaded rods and screw two plastic rod ends on each to the dimension shown. Note that on this strut one ball faces forward and one faces to the rear.

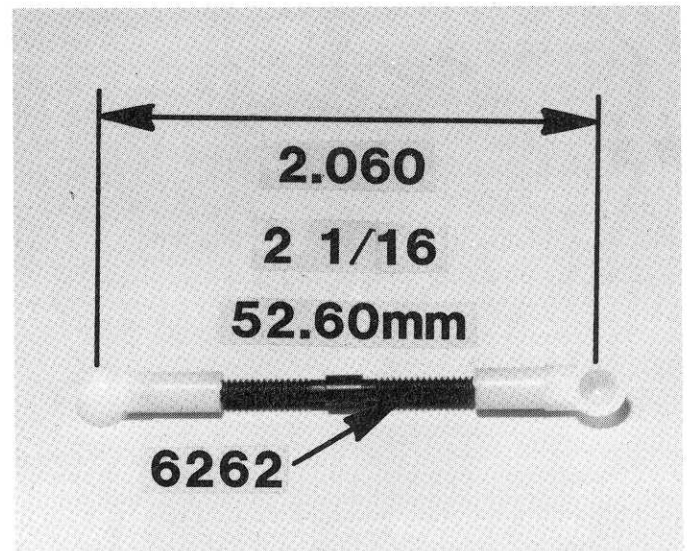

Fig. 88

□ **Fig. 89** Put the strut (A) onto the ball on the bulkhead. Put the half-shaft into the slot. Put the strut (B) on the ball in the hub carrier. It should look like fig. 89 now.

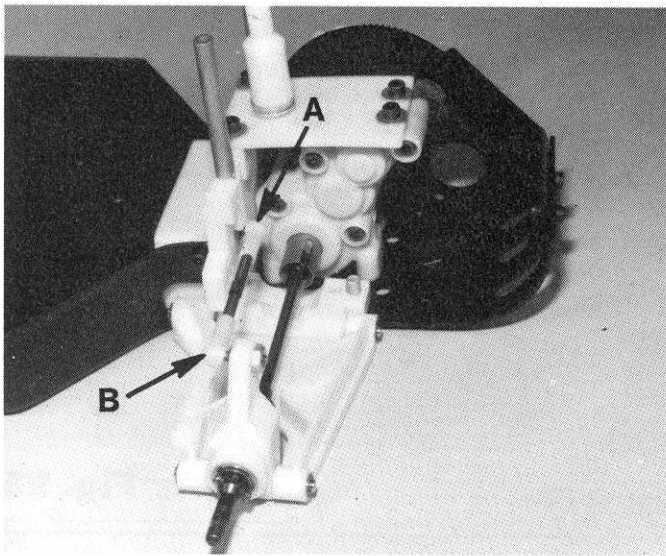

Fig. 89

SHOCK ASSEMBLY

□ **Figs. 90 & 90a** It's easier to build all four shocks at the same time, so take all four of the #6460 and #6458 shafts and install one of the E-clips on each shaft, as shown.

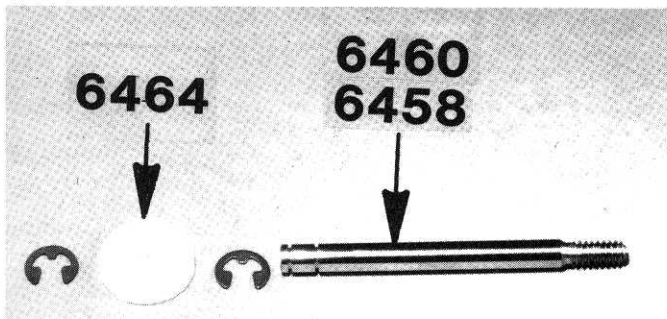

Fig. 90



Fig. 90a

□ **Fig. 91** Now slip the #6464 piston on each shaft, and then install the 2nd E-clip. Make sure both E-clips are fully seated in the groove.

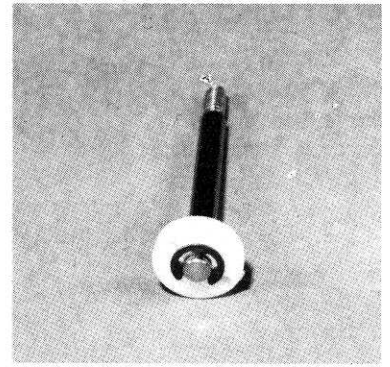

Fig. 91

□ **Figs. 92 & 92a** The #6429 assembly tool makes it quite easy to build shocks. The internal shock parts will be slipped onto the assembly tool in the following order. First, the large split washer, then the small washer, red O-ring, spacer, red O-ring, and small washer. This is exactly as the order shown in the photo.

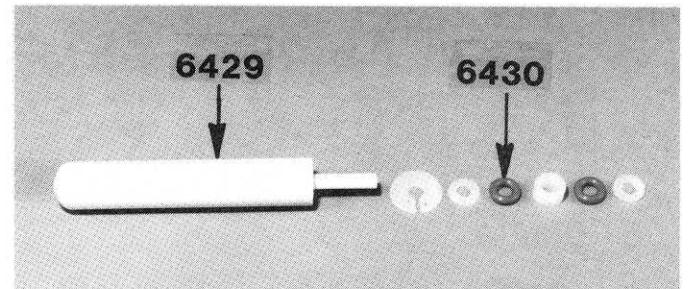

Fig. 92

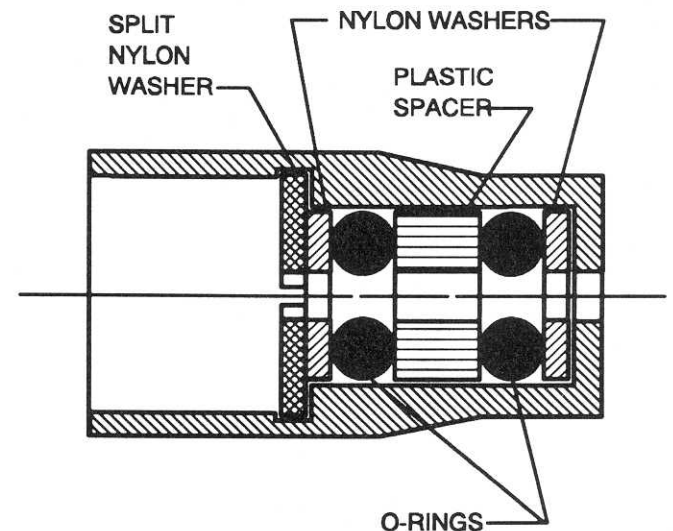

Fig. 92a

Fig. 93 Your kit comes with a very high-quality shock oil, but if you want the best, Associated also has a special Silicone Shock Oil, which we highly recommend. If you're going to use the Silicone Oil, then do not build the shocks with the kit oil, because the two oils will not mix.



Fig. 93

Fig. 95 Put a few drops of oil into the #6437 front and #6435 rear shock bodies to make assembly easier also. We don't want to cut the red O-rings on assembly.

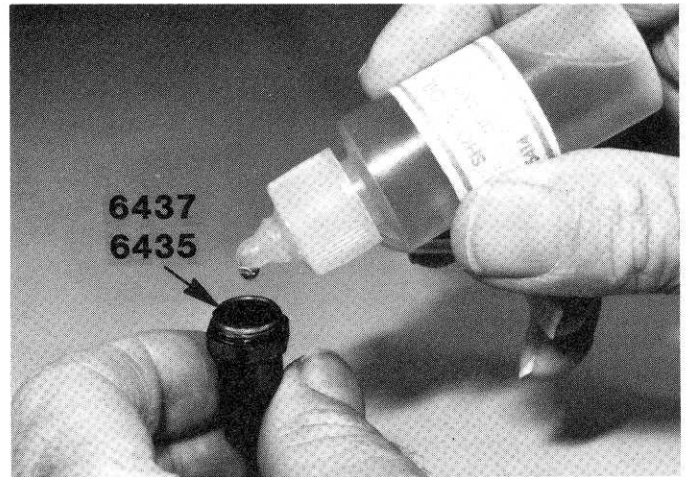

Fig. 95

Figs. 96, 97 & 98 Now take the shock body and the installation tool and push the parts slowly into the shock body all the way down until it bottoms out. Then give it a hard push to seat the split washer. You should be able to hear the washer snap into place. Pull the installation tool out. Look into the shock body to check the installation. **IMPORTANT!** The split ring should look like fig. 97. If it looks like fig. 98, then the washer is not seated in the lock groove and the shock will come apart. **MAKE SURE THE WASHER IS FULLY SEATED IN THE GROOVE.** (Note: To remove the parts, take the installation tool, insert it up through the bottom of the shock, and push the split washer out.)

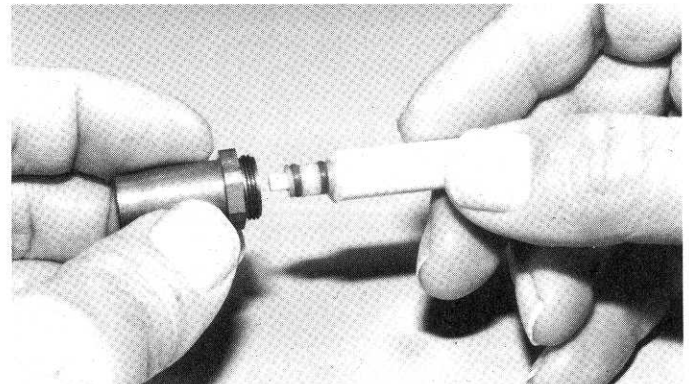

Fig. 96

Fig. 94 Apply a liberal amount of oil to the parts on the installation tool.

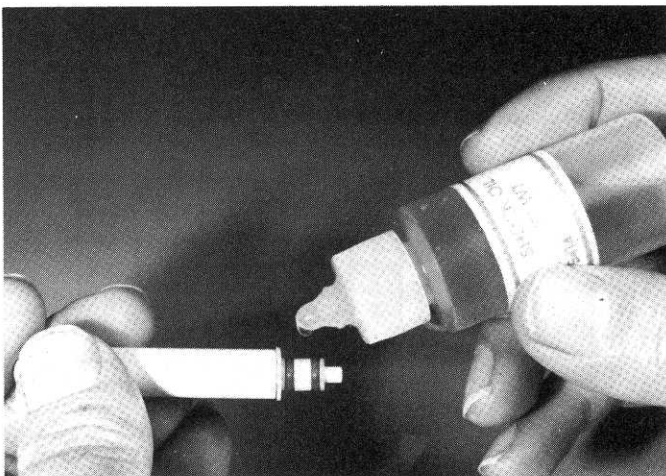

Fig. 94

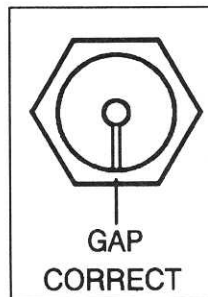

Fig. 97

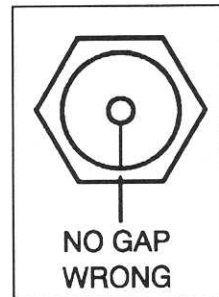

Fig. 98

Fig. 99 After the split washer is fully seated, place a liberal amount of oil on the short shock shaft and slowly push it into the shock, and pull it all the way to the bottom.

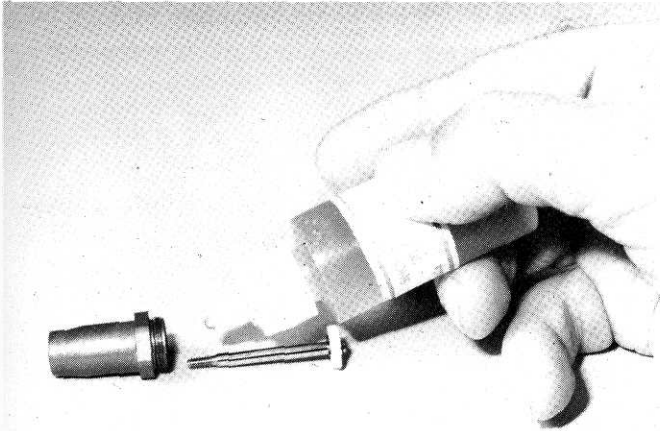

Fig. 99

Fig. 100 In a separate bag will be six #6466 nylon spacers. Slip three of these onto each of the long shafts, all the way up to the piston. These spacers are not used on the front shocks.

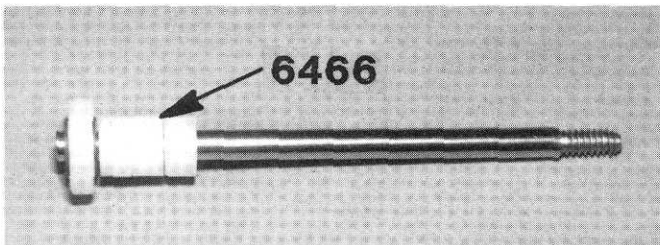

Fig. 100

Fig. 101 Slip the #6469 black O-ring over the threads and seat it flush against the pocket at the bottom of the threads.

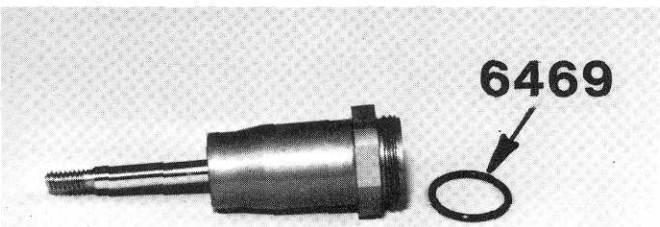

Fig. 101

Fig. 102 IMPORTANT: Thoroughly lubricate the threads in the cap BEFORE installing. IT MUST BE LUBRICATED FOR PROPER INSTALLATION. We'll install it in a minute.

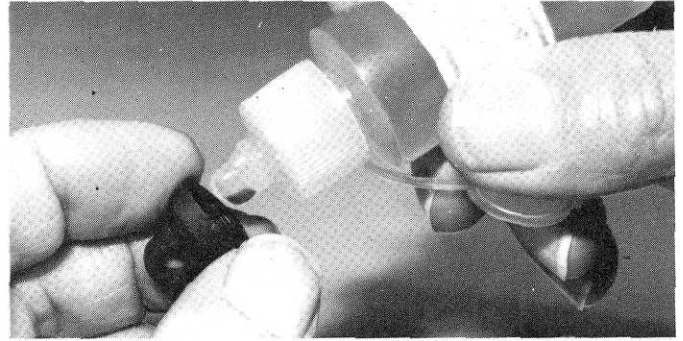

Fig. 102

Fig. 103 Fill the front shocks all the way to the top, but fill the rear shocks only to within 1/16" of the top.

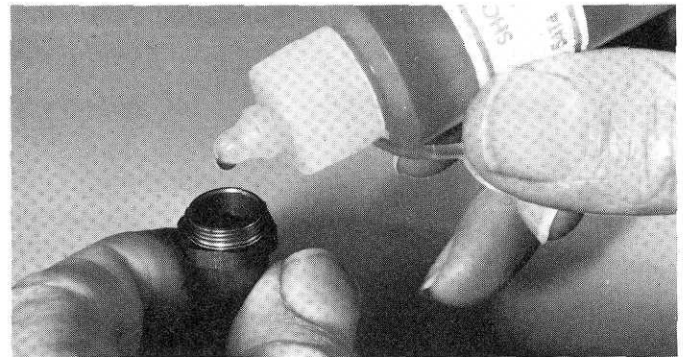

Fig. 103

Fig. 104 Push the shaft up so the piston is up to the top of the body, otherwise there will be too much internal pressure. VERY CAREFULLY screw the shock cap onto the body, making sure the cap goes on straight. BE CAREFUL not to crossthread the cap.

The cap needs to screw all the way down to the shock body. There should be no gap between the cap and bottom where the arrow is indicating. The O-ring will actually be doing the sealing so we must BE CAREFUL not to overtighten the cap and strip out the threads. As soon as the cap comes into contact with the body just turn it a VERY SMALL amount to seat it.

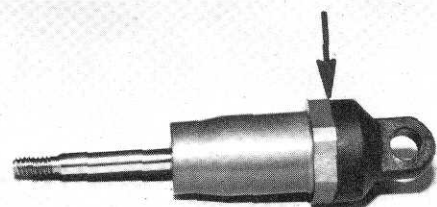

Fig. 104

□ **Fig. 105** From Bag #6-11, install the 2 #6474 spring clamps on the rear shocks. The spring should go over the thin flange. Push the screw through the larger hole of the spring clamp and thread it into the smaller hole to tighten. There should be a 3/8" (9.45 mm) space between the collar and the body hex nut. Tighten the screws just enough to lock the collars. DO NOT overtighten. Slip on the long silver spring. There is also a long gold spring, which is stiffer than the silver spring. The silver spring will work best on most slippery tracks, but you can experiment with the gold spring also, on your track. Take the #6471 plastic rod end and push it onto the metal ball. The easiest way to do this, is to lay the metal ball end on a table, with the flat end on the table. Set the plastic end on the ball and push it in place with your 1/4" nutdriver. Then thread the plastic ball end on the shaft. You'll have to keep the shaft from rotating with a needlenose pliers. Grab the shaft close to the threads so that you don't scratch the part that rides in the "O" rings. With your spring on the shock, snap in the split spring collar.

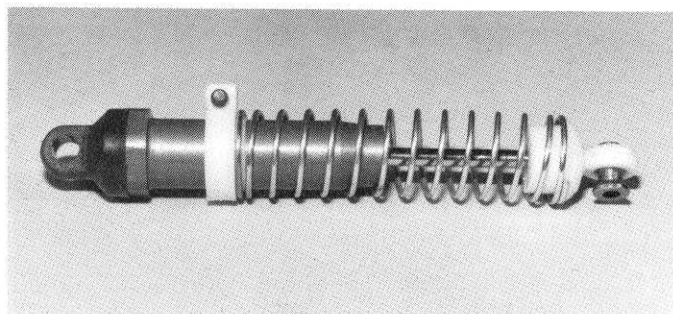

Fig. 105

□ **Fig. 106** On the front shocks, install the spring collars, as shown. Use the short green spring, which is softer than the short gold spring. Again, you can experiment with springs, but start with the green spring. Install the spring cups that go inside the springs, as shown, and then install the plastic ball end. Your shocks are now complete.

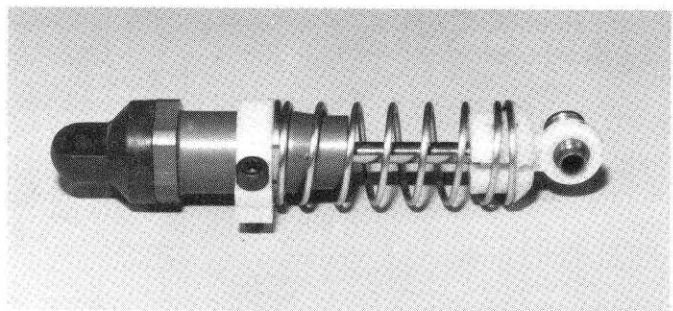

Fig. 106

□ **Fig. 107** Now we'll install the front shocks on the car. The arrow in the photo is pointing to the upper mount. Now slip on an aluminum washer and then screw down and tighten one of the 4/40 plain nuts. Now slip the flanged nylon shock bushing on next, with the flanged end on first.

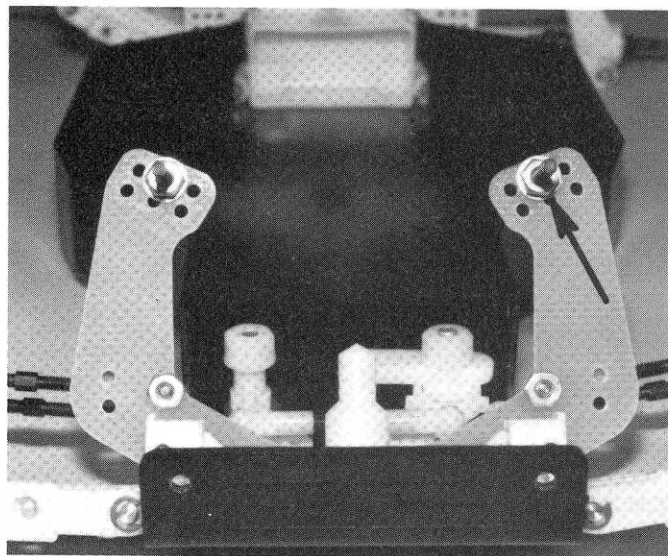

Fig. 107

□ **Fig. 108** Slip the shock on the upper mount and install a locking nut. DO NOT tighten down too tight on this nut or you'll bind up the shock. Squeeze the bottom end of the shock up and then slip the end down into the lower "A" arm slot, with the flat side of the ball to the rear.

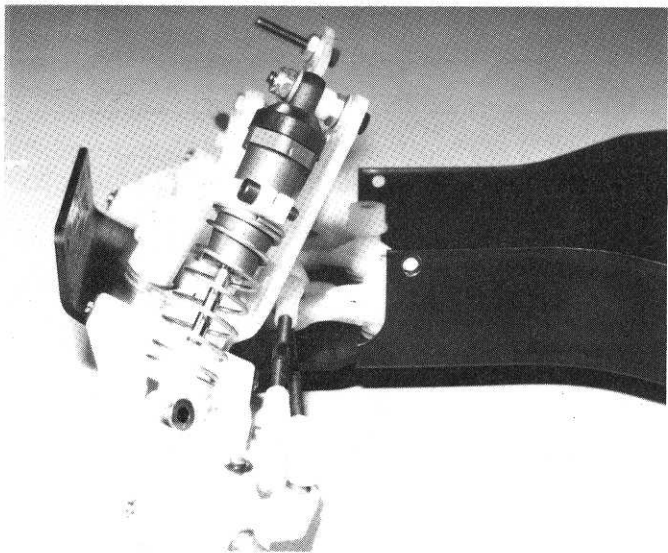

Fig. 108

□ **Fig. 109** The flat side of the ball should be towards the rear as the upper arrow shows. Now, back in Bag #6-1 you have 2 3/4" long screws that only have 1/4" of threads. Use these screws to mount the lower shock balls to the "A" arm, as shown.

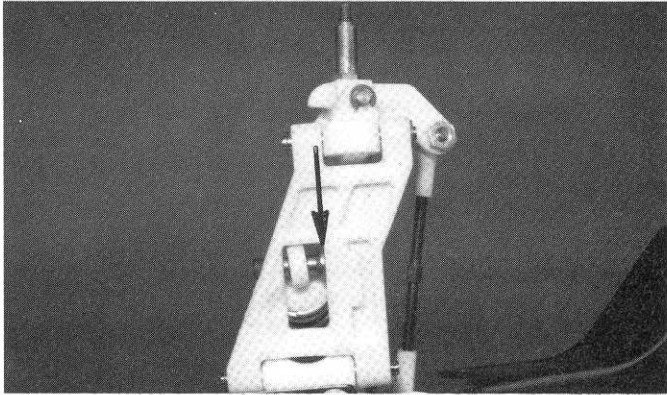

Fig. 109

□ **Fig. 110** Install the R.H. shock.

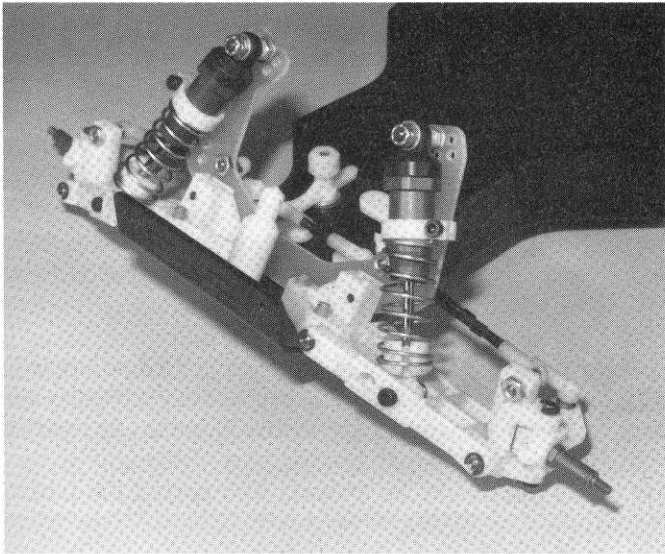

Fig. 110

□ **Fig. 111** In Bag #6-4 are the two #6321 nose brace tubes and 4 Allen button head screws, as shown.

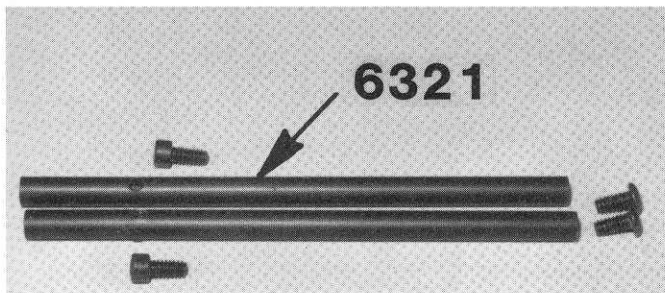

Fig. 111

□ **Fig. 112** These tubes tie in the nose piece very solidly to the chassis. Start by installing the rear screw through the side of the chassis, but do not tighten yet. Install the forward screw through the front of the nose piece into the end of the rod and tighten down. Now tighten the rear screw. Install the 2nd brace.

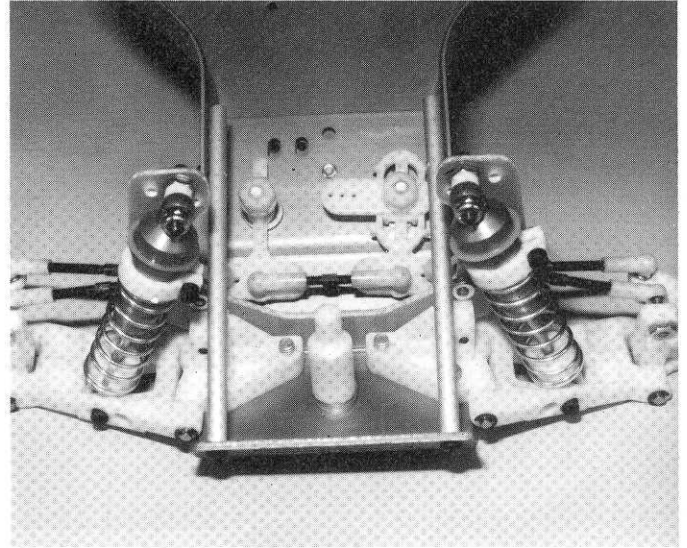

Fig. 112

□ **Fig. 113** Also in Bag #6-4 is the #6378 rear shock strut. Assemble this to the rear bulkhead with the 4 Allen screws, as shown.

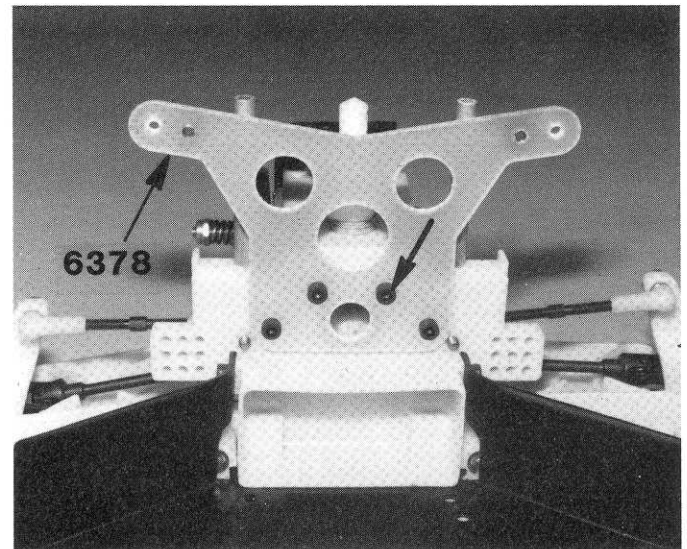

Fig. 113

□ **Fig. 114** It's time to install the rear shocks. From Bag #6-9, install one of the Allen screws through the fiberglass strut from the rear. Then, install a plain nut and an aluminum washer next. Slip a bushing in the shock, with the flange to rear, and slip the shock on the screw.

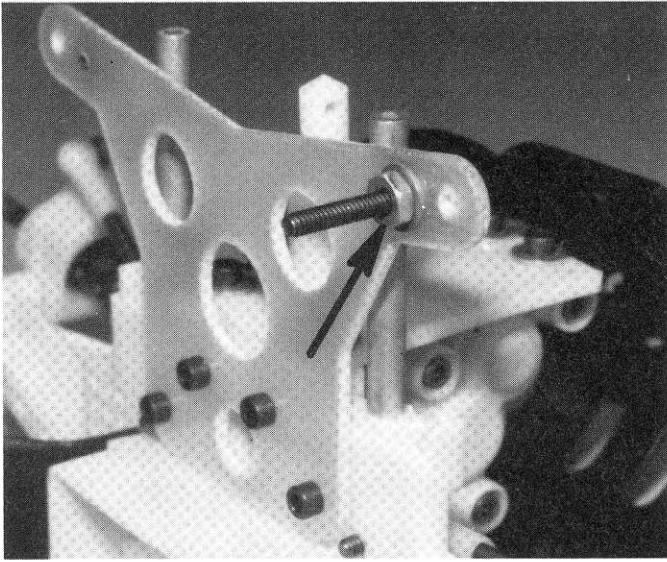

Fig. 114

□ **Fig. 115** Install a locking nut next. Do not overtighten the nut, it is only necessary for the nut to take up the end play.

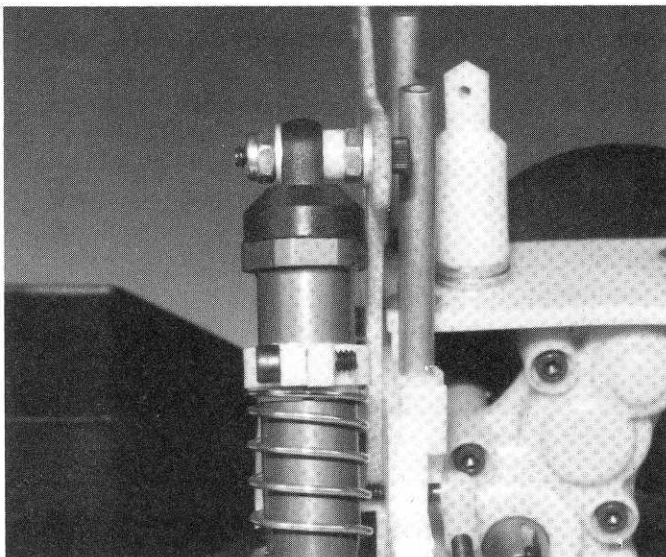

Fig. 115

□ **Fig. 116** For the shock bottom installation we want the flat part of the metal ball end to be against the "A" arm, as shown. In the "A" arm, there are 4 holes. Install it in the outside hole. Slip a washer on the screw, and install the screw.

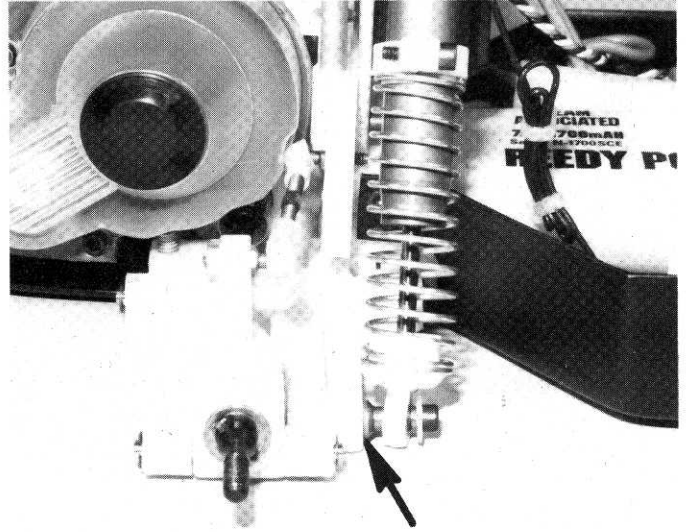

Fig. 116

□ **Figs. 117 & 118** Time to put the horsepower in the car. Using ROSIN core solder, solder the motor lead wires and filter capacitors to the #6500 motor, as per the instructions included in the motor bag. Take your pinion and install the pinion, as shown. The end of the pinion should be even with the end of the shaft. NOTE: The motor and pinion do not come with the kit.

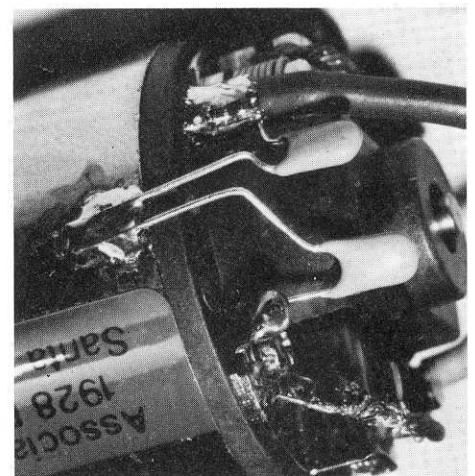

Fig. 117



Fig. 118

□ **Fig. 119** Remove the gear cover. In the motor bag are 2 metric motor mounting screws. These screws have finer threads and are ONLY used to mount the motor. Slip the motor in the motor mount and start the bottom screw in first. Do not tighten all the way down yet. On the top screw, put a washer on the screw and screw it in, but not tight. Now we'll set the gear mesh. By moving the upper screw, forward or back, we'll be moving the motor closer to, or away from the plastic spur gear. What we want to do is to get the metal pinion gear as close to the plastic spur gear as we can without binding up the gears. The easy way to check this is to put your finger on the plastic gear and see if you can rock it in the teeth of the metal gear. The 2 gears should be as close as possible, while still being able to very slightly rock the plastic gear. When you have this correct spacing, tighten down on the 2 motor screws and re-check the gear spacing. An incorrect gear mesh can result in a huge power loss, so do it correctly.

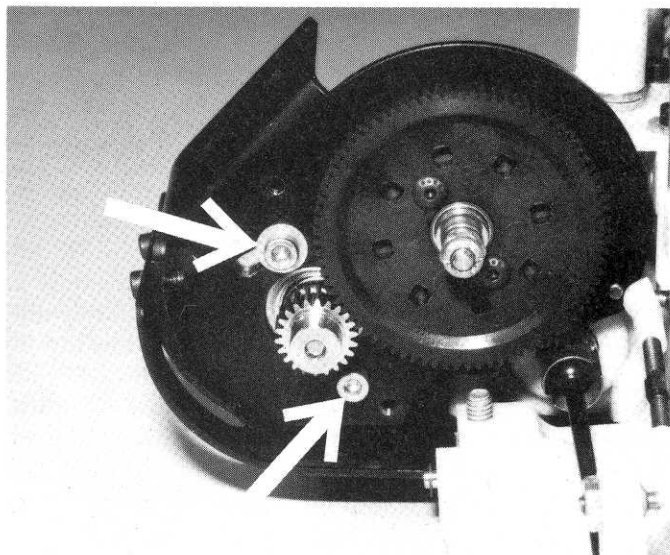

Fig. 119

□ **Fig. 120** Reinstall the dust cover.

CAUTION: To remove the motor, you must first remove the dust cover. You will then have 4 screws out that look the same. But if you mix up the dust cover screws with the motor screws, you will strip out the threads. Keep the motor screws with the motor, and the dust cover screws with the dust cover. Also, DO NOT try to use aluminum screws to attach the dust cover because they will break off in this installation.

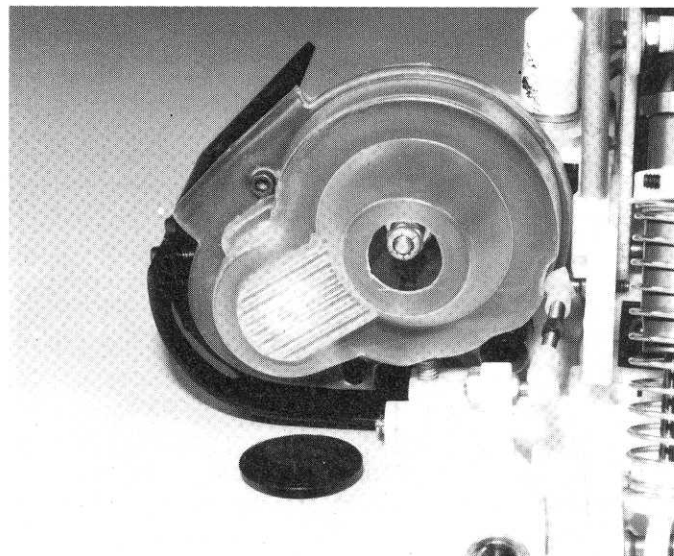

Fig. 120

□ **Fig. 121** Install the #6334 battery cup with two buttonhead screws through the bottom of the chassis. Install the battery strap with two 4/40 screws and clip, as shown.

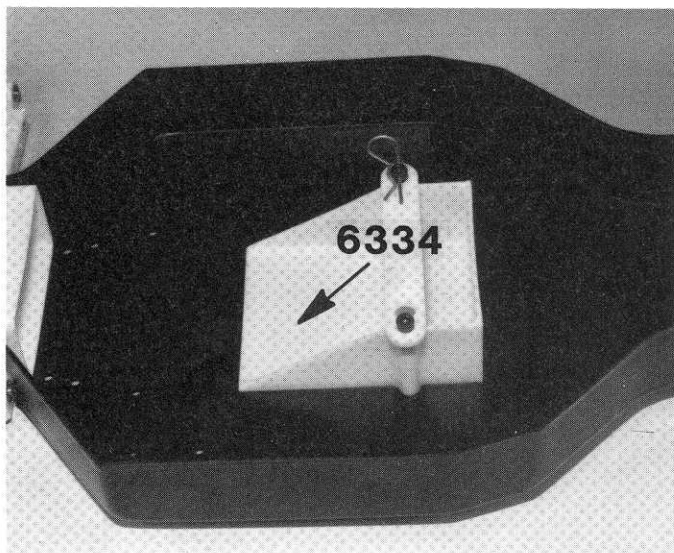

Fig. 121

RADIO INSTALLATION

We're ready to install the radio. If you haven't purchased a radio yet a good choice would be one of the 2-channel steering-wheel systems made by Futaba or Airtronics. However, many other radios, including stick models, can be used in the car. The higher torque medium sized servos are preferred for steering (like the Futaba S31SH, S131SH, S128, S131S, S9101, and Airtronics 94737 and 94151.)

STEERING SERVO

□ **Fig. 122** In Bag #6-6, take out 2 of the #6336 plastic servo mounts. You'll have to drill the mounts for your particular servos. If you have S32 servos, line up your servo with the mounts, so that there will be about 1/16" (1.6mm) clearance between the servo and the chassis plate and mark the hole locations on the mounts. Drill two #43 (2.3mm) holes in each mount on the side away from the chassis mounting hole, which will be on the bottom of the mount. You'll notice that the chassis has 2 sets of servo mounting holes. A short set and a long set. With 2 different sets and by rotating the servo mounts 90 deg, you will be able to mount most servos. Put the rubber grommets on the servo and attach the servo to the mounts with 4 but-ton-head Allen screws and washers, as shown.

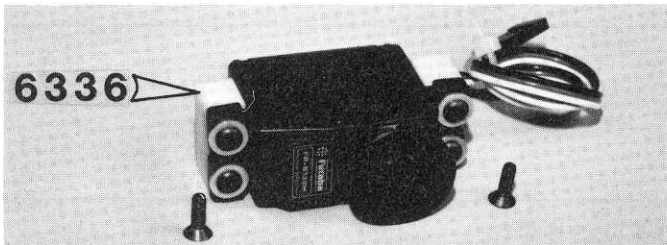

Fig. 122

□ **Figs. 123 & 123a** Install the servo to chassis with the 2 flathead Allen screws shown in fig. 122. You'll have to install 2 washers between the rear mount and chassis for proper alignment. Fig. 123a shows the proper holes to use with small servos.

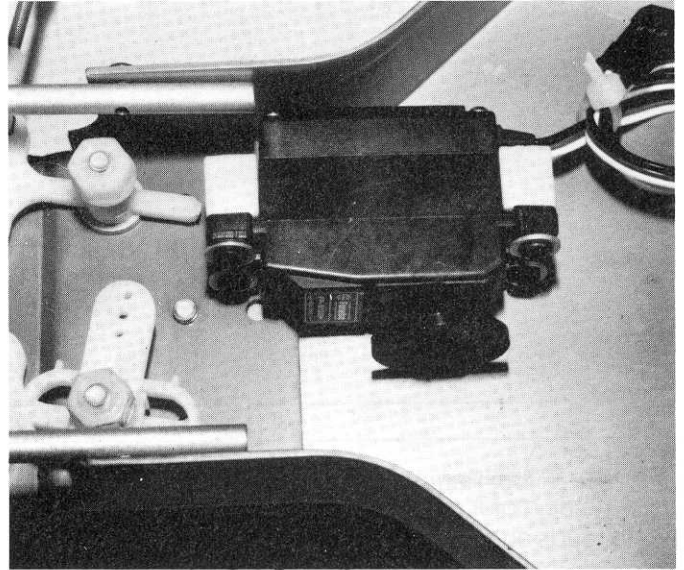

Fig. 123

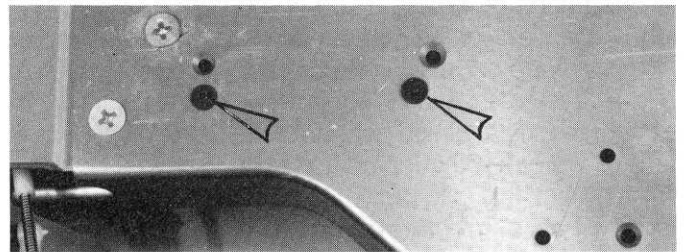

Fig. 123a

□ **Fig. 124** Out of Bag #6-2, take the piano wire linkage and set collars. Turn the servo output arm to the left and right stops and then center the arm between these 2 stops. It will not be exact, but it will be close enough for now. We'll center it exactly with the radio later. Slip one of the "Z" bend arms in the servo arm, as shown. The "Z" bend arm will be easier to install in the servo saver arm if you take your X-acto knife and rotate it in the hole to bevel it slightly. The arrow in the photo is pointing to a slight bend that we want to put in this wire to help clear the collars from the servo. Put a slight bend in the arm and then slip it in the center hole, as shown. Center the servo saver and install and tighten both lock collars.

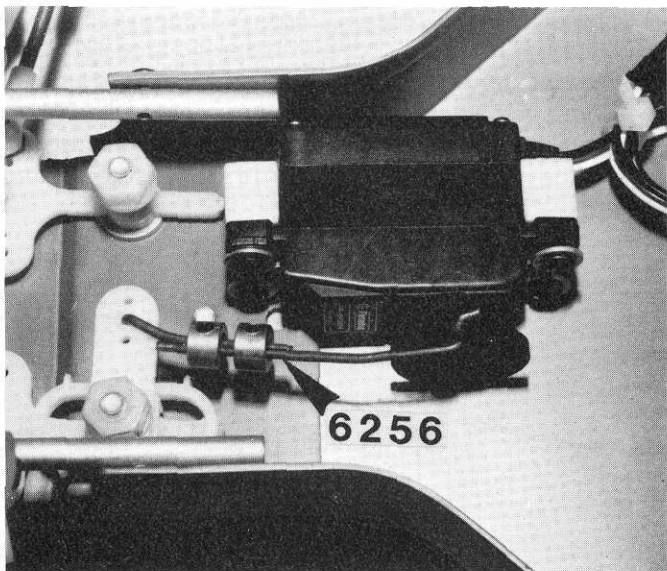

Fig. 124

Fig. 126 Linkage is the same as for small servo but may require slightly more bend.

In the last few pages of this instruction manual are diagrams and photos of electrical wiring and radio and speed control installations.

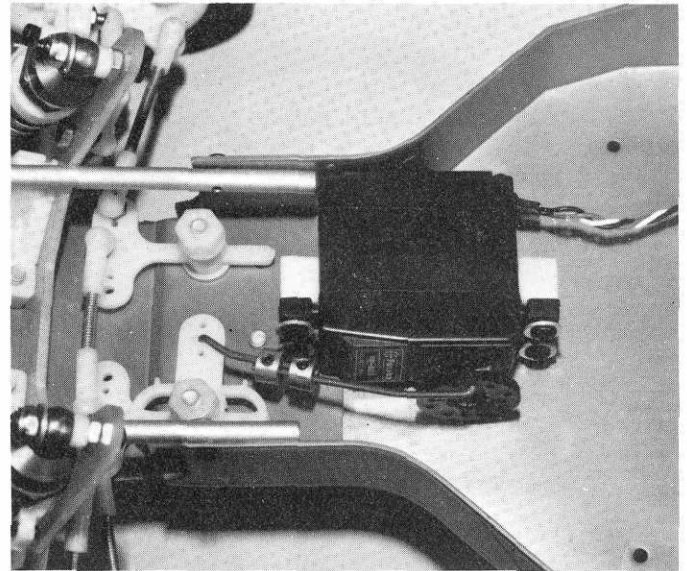

Fig. 126

SPECIAL INSTRUCTIONS: MEDIUM STEERING SERVO

Fig. 125 Medium sized servos would include Futaba S31, S131, S28; Airtronic 94461; and Novak NES1A. Follow the same procedure as for the small servo but use the wider spaced mounting holes in the chassis.

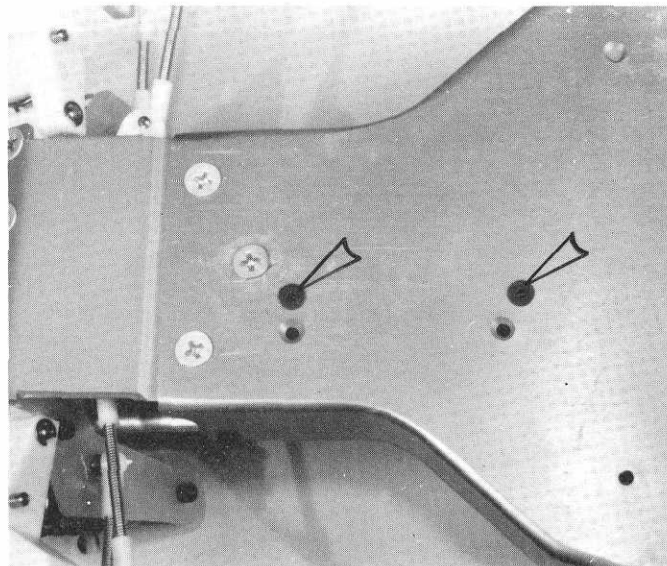

Fig. 125

TIRE AND WHEEL ASSEMBLY

Fig. 127 Take the front and rear tires and slip them over the wheels, as shown, and then finish mounting the tires. Make sure they're all fully seated so they will run true. Team racers will glue the tires to the wheels with Hot Stuff.

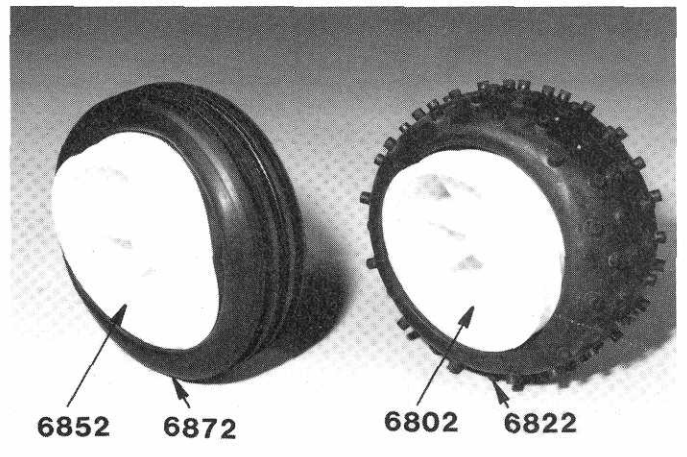

Fig. 127

□ **Figs. 128 & 128a** Install two ball bearings in each front wheel, and then slip the wheels on the front axle, then a washer and then the locknut. Tighten the locknut and make sure the wheel spins freely. If it doesn't, back off on the locknut.

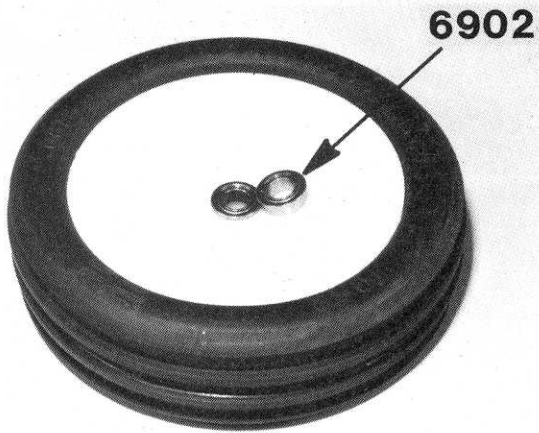

Fig. 128

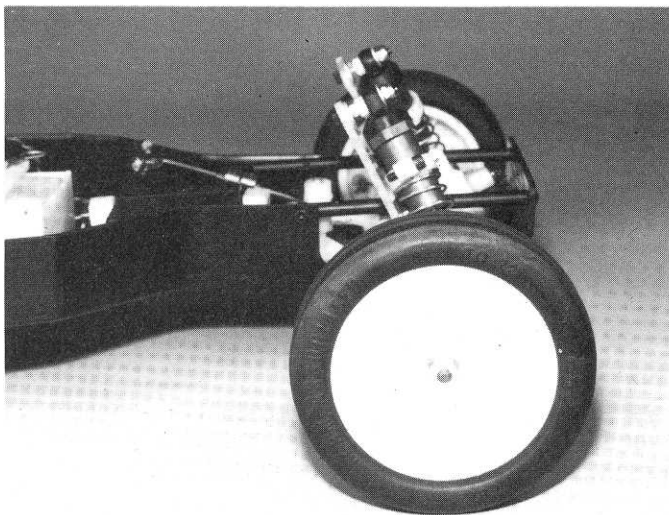

Fig. 128a

□ **Fig. 129** Slip the wheels on the rear axles. If they go on tight, screw them on the axle making sure the slot in the wheel aligns with the pin in the axle. Screw the locknut on. Some rear wheels will go on the axles a little tighter than others. When you're ready to remove the wheel, remove the nut, hold the wheel from the backside and tap the end of the axle until the wheel moves a little bit. Then you can simply unscrew it off the axle.

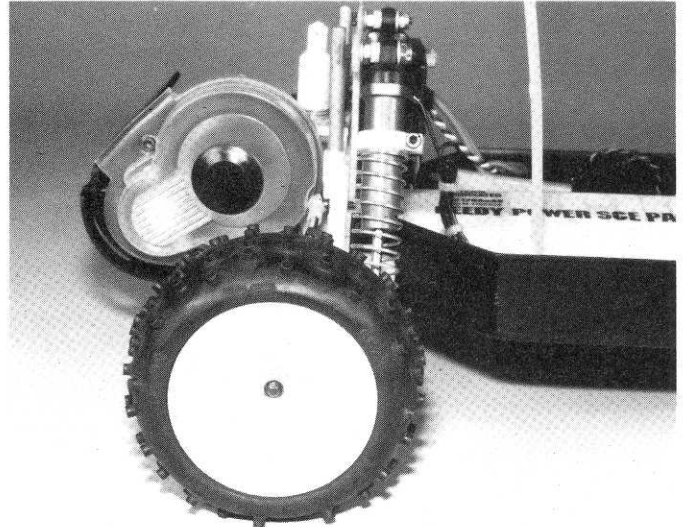

Fig. 129

□ **Fig. 130** The driver can be painted to look quite life-like. If you paint the helmet and visor on the inside, they will have a glossy appearance. Then if you paint the rest on the outside, it will be very life-like. You can use the small brush on paint bottles available in hobby stores. The driver should be trimmed as shown, then it will slide up into the body, and 2 pieces of tape will hold it in place.

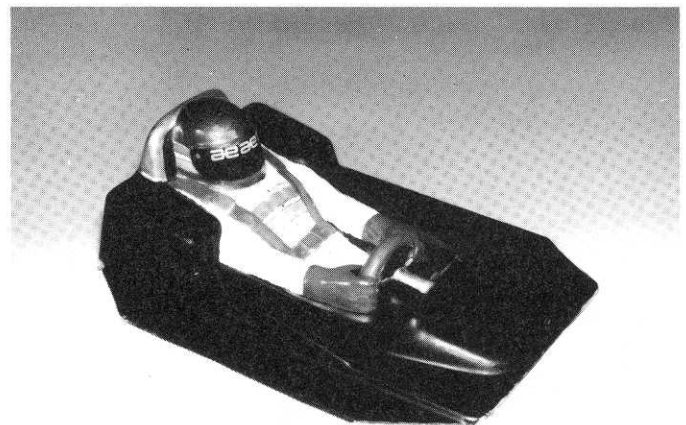

Fig. 130

□ **Fig. 131** The body can be painted before you mount it, however it might be easier for you to mount it while it's clear because it will be easier to locate the holes for the body mounts and wing tubes. This photo shows the trim lines for the front of the body and the front body mount hole.

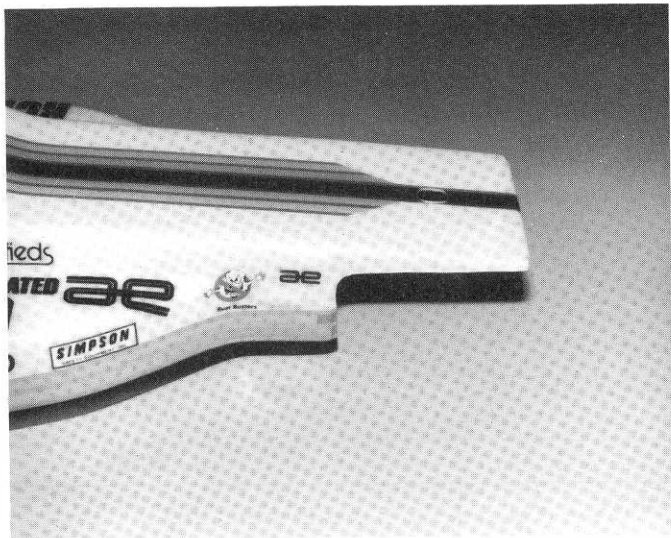

Fig. 131

□ **Fig. 133** Trim a little of the body and slip it on. Keep trimming a little at a time until it clears the shocks. Cut out the body mount hole and the 2 wing tube holes. When you've got the body fitted, it's time to paint the body and wing. The body is painted on the inside and the wing is painted on the underside. There are 2 different ways to paint the body. By either brushing it on or spraying it on. The body is made of Lexan polycarbonate. In hobby shops, you can find special Lexan or polycarbonate paints made for these type bodies, to brush on. Do not use any other type brush-on paints. If you want to spray it on, one of the best type of spray paints for Lexan or polycarbonate is Pactra, available in most hobby shops.

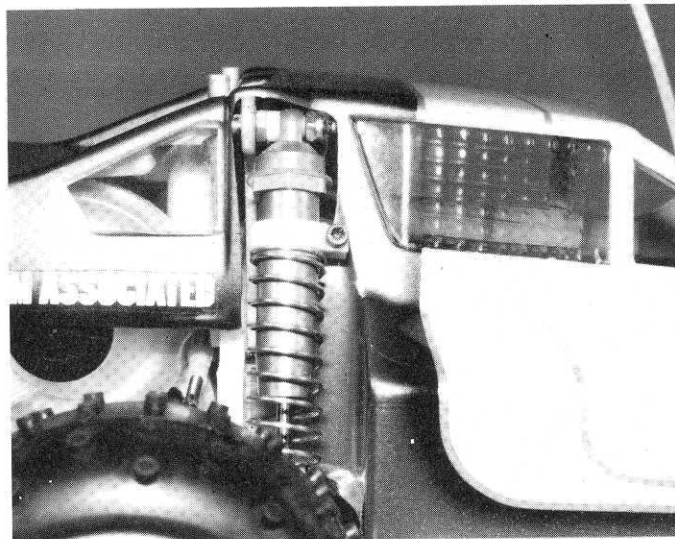

Fig. 133

□ **Fig. 132** The rear of the body must be trimmed like this to clear the shocks.

NOTE: Save the trimmings to use for testing paint.

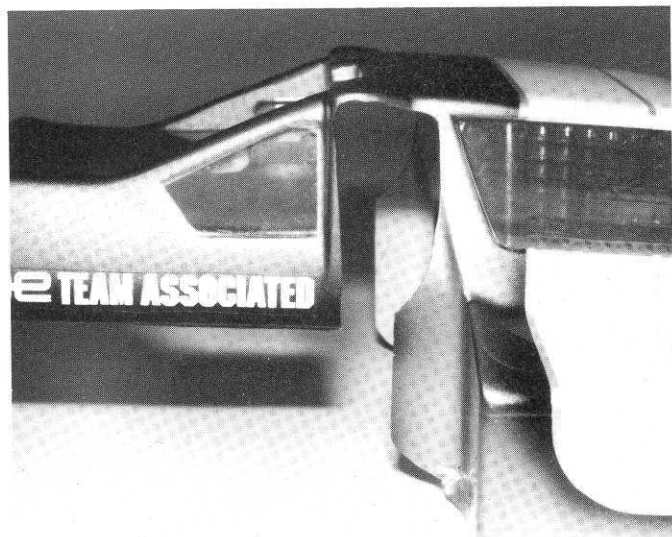

Fig. 132

Fig. 134 Now you'll have to figure out your paint scheme and mask the body off. Use automotive masking tape for best results. You always want to paint the darkest color first, and the lightest color last. So, in the case of this wing, the darkest color, which is towards the top of the photo, would be painted first. This means the first thing you mask off is the section which will be painted white. The next section you mask off is the lightest color next to white and so on. After you've painted the darkest color, you peel off the next layer of masking tape and paint the next lighter color and so on. When you paint the body, put some masking tape on the outside of the body at the body mount holes and wing tube holes and at the shock cutout holes so the excess spray does not get on the outside of the body.

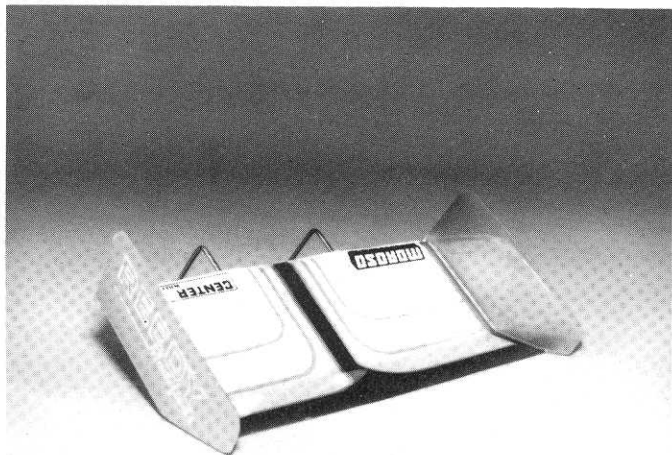

Fig. 134

Fig. 135 Mount the wing as shown in the instructions in the wing bag.

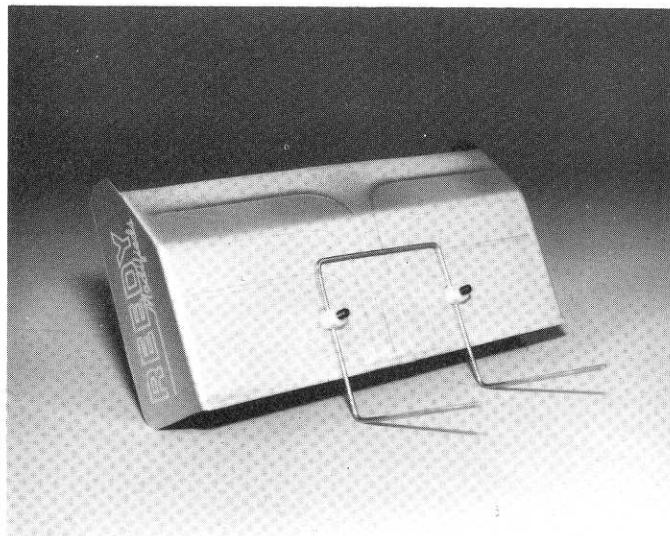

Fig. 135

Fig. 136 Mount the body, with the body clips and wing, on the car, and then pat yourself on the back. YOU DID FANTASTIC!!



Fig. 136

RC10 WIRING DIAGRAM

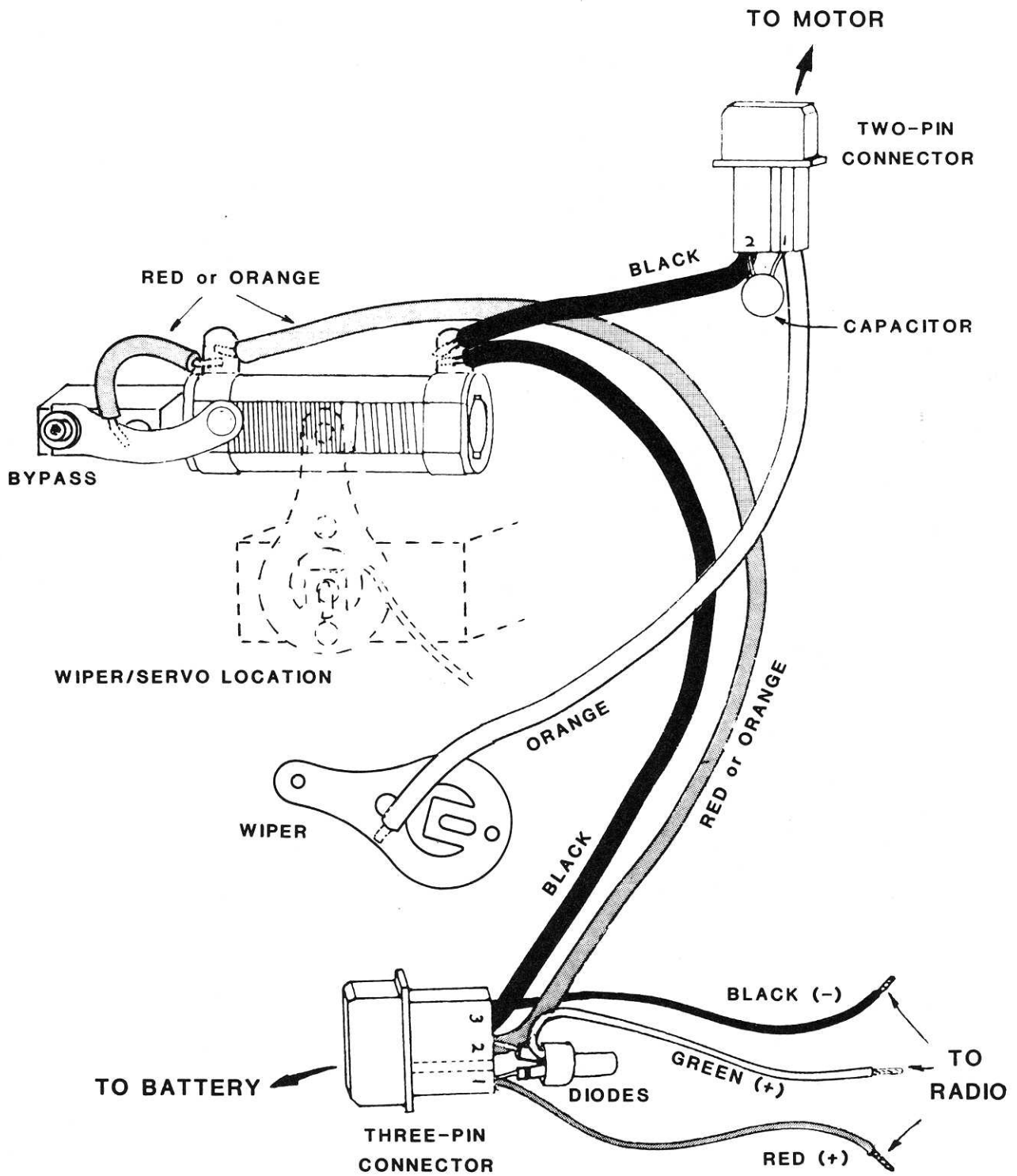

NOTE: Use green and black radio leads with 6-cell pack. Use red and black radio leads with 7-cell pack.

Fig. 208

BATTERY WIRING

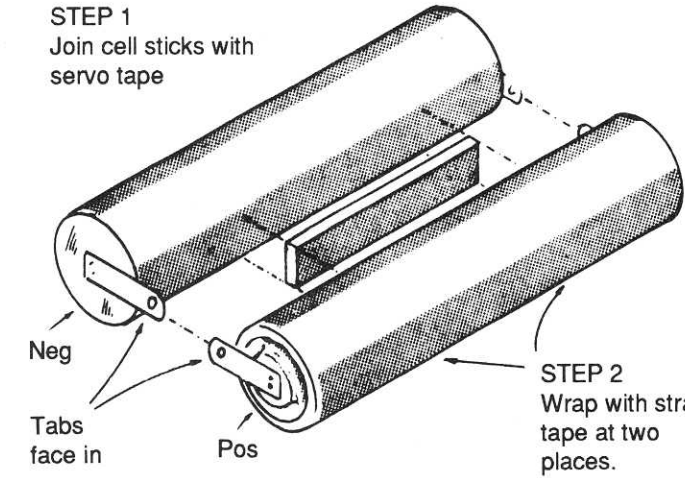

STEP 3
Join and solder tabs at one end of pack.

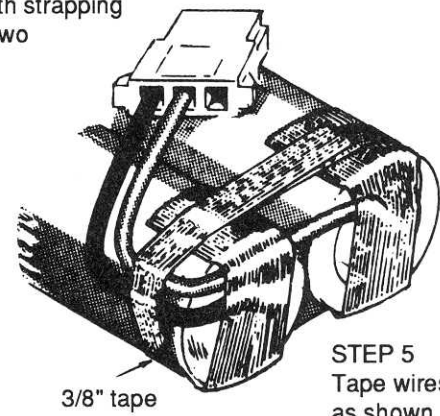
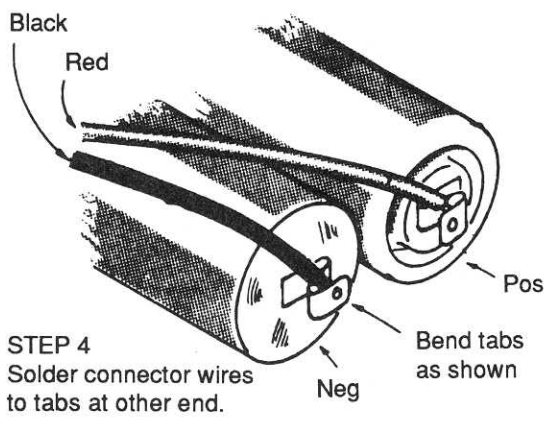
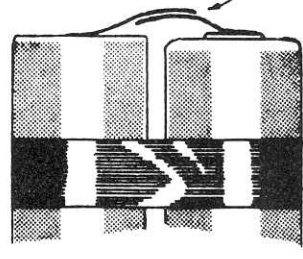

STEP 5
Tape wires to pack as shown. Use 3/8" tape where indicated.

Fig. 209

RC10 CIRCUIT SCHEMATIC

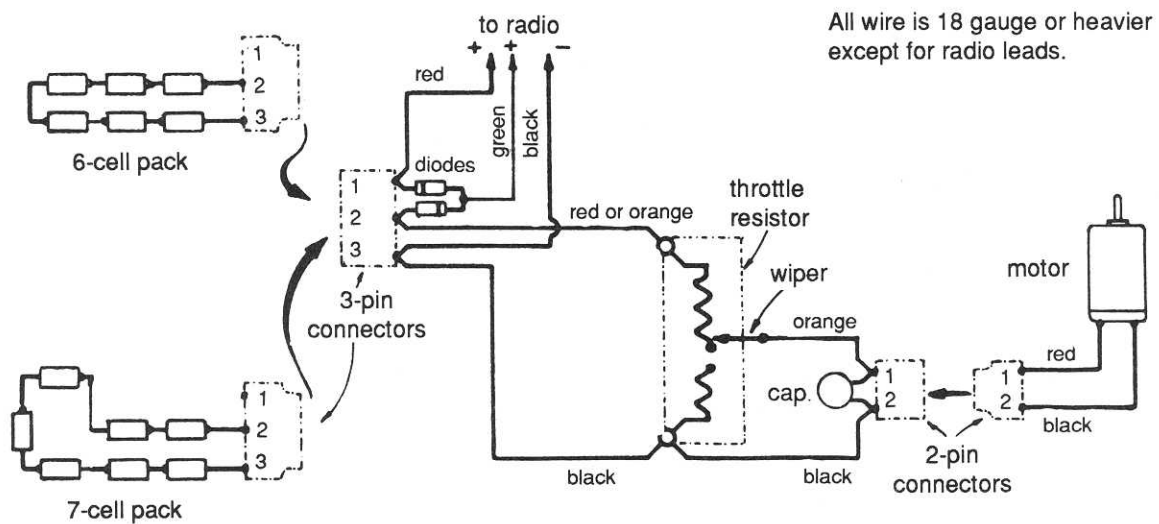
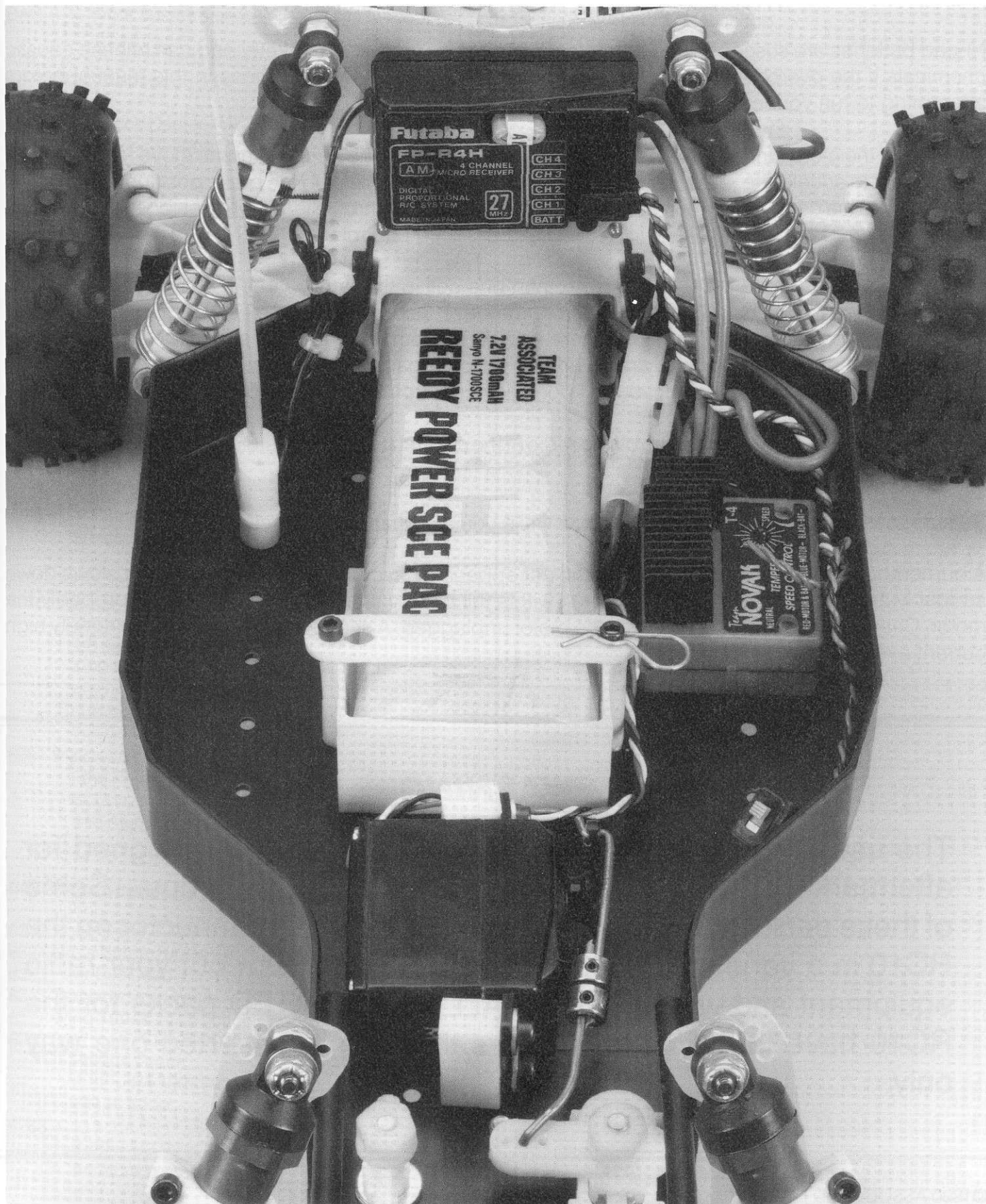

Fig. 210

BATTERY WIRING & RADIO INSTALLATION DETAIL



CAUTION

Ni-cad batteries are susceptible to damage when overcharged at a high rate, and can release caustic chemicals if the overcharge is severe. Read the battery charging instructions in this manual before attempting to run your car.

Do not stall the motor under power. If the car stops suddenly on the track, or fails to move forward when you attempt to accelerate, push the throttle control on your transmitter to the brake position immediately and attend to the car. A small rock can stall the gears, and if the throttle is left in the on position the result can be a burned out motor or resistor (or electronic speed control unit).

If you run your car to the point where more than one cell in the pack is completely discharged, it is possible to lose radio control of the car before the drive motor stops completely. For this reason you should not operate your car in an area where it could be harmed or cause harm, such as near a busy roadway or a pool of water. Usually radio control will be regained as soon as you pick up the car and the motor is allowed to free-run. If you still don't have control, then you should unplug the motor.

When you stop running your car, turn off the radio at the car first (with the resistor in the off position) before turning off the transmitter.

Be sure that the resistor is in the off position while you are charging the battery.

A burned-out or shorted motor can make the car appear to have radio problems. If the car slows down suddenly and the radio acts erratically even with a full battery charge, then the cause is probably the motor. Check the range of the radio with the motor unplugged. A shorted motor will draw extremely high current even under no-load conditions.

WARNING

The use of Ni-cad packs with two-pin connectors, designed for aftermarket or for other brands of cars, can be hazardous. Some of these packs can be plugged into the three-pin connector on the RC10 in a variety of incorrect ways that can burn out your radio equipment and wire harness. **ALL ASSOCIATED** packs for the RC10 have three-pin connectors that can be inserted one way only.

TEAM CAR KIT CONTENTS

BAG 6-1 - Front Suspension Bag

6206 Front A arms "wide track"	pr
6207 Front Suspension Mount	pr
6213 Front Block Carrier 15 degpr	
6217 In line Axle Steering Blk	pr
6218 In line Front Axle	pr
6223 King Pin	pr
4-40 shcs special for front shock mounting	pr
6226 Inner Hinge Pin	
6227 Outer Hinge Pin	
6231 Front Shock Strut Wide "A" arms	
4-40 x 1 3/4 Turnbuckle	pr
6242 4-40 Nylon Insert Locknut	pr
3216 #4 Steel Washer	pr
6280 8-32 x 1/2 100 deg Alum Fthd	
Phillips Green	6
4-40 x 1/2 S.H.C.S.	2
6299 E Clips	16

BAG #6-2 - Servo Saver and Steering Linkage

6255 Servo Saver Plastic Only	
6256 Linkage	
Z Bend 1/16 Piano Wire	2
1/8 set screw Collar	2
4-40 x 1/8 Setscrew	2
4-40 x 2.06 Turnbuckle (Tie Rod)	2
4-40 x 1.00 Turnbuckle	1
6281 8-32 x 7/8 100deg Alum	
Fthd Phillips Green	2
8-32 Nylon Locknut	2
#10 Alum Washer	2

BAG #6-4 - Chassis Parts

6309 Nose Piece, black	1
6321 Nose Brace Tubes, black	2
6323 Rear Bulkhead	1
6325 Transmission Brace	1
6327 Wing Tubes	
6280 8-32 x 1/2 100° Alum Flathead	
Phillips Green	2
8-32 x 1/4 100° Steel	
F.H.P. Silver	1
6288 4-40 x 1/4 B.H.C.S.	4
4-40 x 1/2 S.H.C.S.	6
#4 Alum Washer	4
6378 Rear Shock Strut	

BAG #6-5 - Body Mount Kit

6330 Plastic Body Mount Post	2
6332 Hood Pins	4
#10 Alum Washer	4
6280 8-32 x 1/2 100deg Alum	
F.H.P. Green	2
6281 8-32 x 7/8 100deg Alum	
F.H.P. Green	1

BAG #6-6 - Servo Mount Kit

6336 Servo Mount Plastic	4
6292 4-40 x 3/8 F.H.S.C.	4
4-40 x 5/16 B.H.C.S.	8
#4 Alum Washer	10

BAG #6-7 - Battery Cup

6334 Battery Cup	pr
6335 Battery Holddown Strap	2
6332 Hood Pins	4
4-40 x 1/2 F.H.S.C.	4
4-40 x 3/8 S.H.C.S. W/hole	2
4-40 x 3/8 S.H.C.S. Pln 2	

BAG #6-8 - Rear Suspension Kit

6355 Rear A Arms	pr
6360 Rear Suspension Mounts	pr
6366 3deg Rear Hub Carriers	2
6371 U-joint	
6375 Stub Axle Roll Pin	2
6380 Rear Inner Hinge Pins	pr
6381 Rear Outer Hinge Pins	pr
4-40 x 1 3/4 Turnbuckles	2
6387 Bronze Oilite Bushing/w	
Washer	pr
6280 8-32 x 1/2 100 deg Alum	
Flathead	4
4-40 x 5/16 S.H.C.S.	4
6299 E Clip	16
8-32 Nylon Insert Alum	
Locknut	2
6373 Rear axle spacer	10

BAG #6-9 - Rear Shock Bag

6435 Rear Shock Body .4x132	2
6439 End Cap, black	2
6458 Shock Shaft 1.32 Stroke	2

6464 Piston	2
6430 Rebuild Kit	
Nylon Snap Ring	4
Black "O" Ring	4
Nylon Spacer	2
Small Nylon Washer	2
Silicone "O" Ring	4
E Clips	12
6466 Down Stops	6

BAG #6-10 - Front Shock Bag

6473 Shock Body .71 Stroke	2
6439 End Cap, black	2
6460 Shock Shaft .71 Stroke	2
6464 Piston	2
6430 Rebuild Kit (See Bag 6-9)	
6470 Mounting Kit (See Bag 6-9)	
Nylon Spacers	

BAG #6-11 - Oil, Springs, Clamps

5414 30 wt Shock Oil	
6478 Spring Rear 2.75 x .042	
Silver	2
6479 Spring Rear 2.75 x .045	
Gold	2
6496 Spring Front 1.3 x .042	
Silver	2
6497 Spring Front 1.3 x .045	
Gold	2
6474 Clamps and Cups includes	
Spring Clamp	4
Spring Cup	4
4-40 x 3/8 S.H.C.S.	4
6480 Spring, Rear 2.75 x .041	
Green	
6494 Spring, Front 1.30 x .041	
Green	

BAG #6-12 - Transmission Bag

6560 Stealth Transmission Kit, Complete	1
6563 Complete Ball Bearing Set	9
6565 Transmission Case, Left & Right Sides	set
6566 Felt Gasket	1
6568 Spur Gear Screws	4
6569 Motor Plate Spacers and End Cap	
6570 Idler Shaft and Gear	
6571 Drive Gear/Shaft Assembly with Roll Pin	
6572 Drive Shaft Roll Pins	6
6573 Diff Thrust Washers	2
6575 Diff Thrust Bolt, Thrust Bearing Cover, Dogbone Spacers and Locking T-nut	

6576 Carbide Thrust Diff Balls, small, 5/64"	6
6577 Diff Outdrive Hub, right	1
6578 Diff Outdrive Hub, left	1
6579 Diff Drive Rings	2
6580 Diff Gear	1
6581 Carbide Diff Balls, large, 3/32"	12
6582 Diff Thrust Spring	1
6583 Torque Control Hub, inner	1
6584 Torque Control Hub, outer	1
6585 Clutch Disk	1
6586 Torque Control Thrust Bearing and Thrust Washers	
6587 Torque Control Spring and Locknut	
6588 Black Grease	1
6589 Diff Bearings, 5/32 X 5/16, plain	2
6590 Mounting Hole Drill Guide	1
6591 Stealth Diff Lube	1
6592 Allen Wrench Set, 1/16, 5/64, 3/32	
6607 Motor Mounting Plate	1
6608 Gear Dust Cover	1
6903 Ball Bearings, 3/8 X 5/8	2
6906 Ball Bearings, 3/16 X 3/8	2
6325 Transmission Brace	1

BAG #6-14 - Ball End W/Cups

6273 Ball End Long	6
6270 Ball End Short	8
4-40 Plain Hex Nut	8
6274 Plastic Ball Cup	14

BAG #6-15 - Gear Bag

6693 81 Tooth 48 Pitch Gear Spur	
6955 Turnbuckle Shock Wrench	
6191 Headlights & Knockoffs	
6338 Antenna Mount and Tube	
6950 Allen Wrench Set	
Wire Ties 4"	
3714 Servo Tape	
6301 Black Chassis	
6121 Viper Body	
6182 High Down force Wing Kit	
6180 Clear Driver	

REAR WHEEL

6802 One Piece Glue-on Rear Rims, 2" pr

REAR TIRE

6822 Cut-Down Spikes pr

(Optional tires:

6821 soft, medium

6820 soft, pyramid spikes)

FRONT WHEEL

6852 One Piece Glue-on Front Rims,
2 1/8" pr

FRONT TIRE

6872 3 Ribbed, Grooved pr

(Optional tires:

6871 soft, medium)

6902 Ball Bearings, 3/16 x 5/16, flanged 2

897 Ball Bearings, 1/4 x 3/8, flanged 2

SAVE THIS BOOKLET!

**MORE THAN AN INSTRUCTION
MANUAL, IT'S ALSO A HANDY,
PICTORIAL SUPPLEMENT TO
TEAM ASSOCIATED'S 1/10
SCALE CATALOG.**

**REFER TO THIS MANUAL FOR
PART NUMBER AND NAME
WHEN ORDERING.**

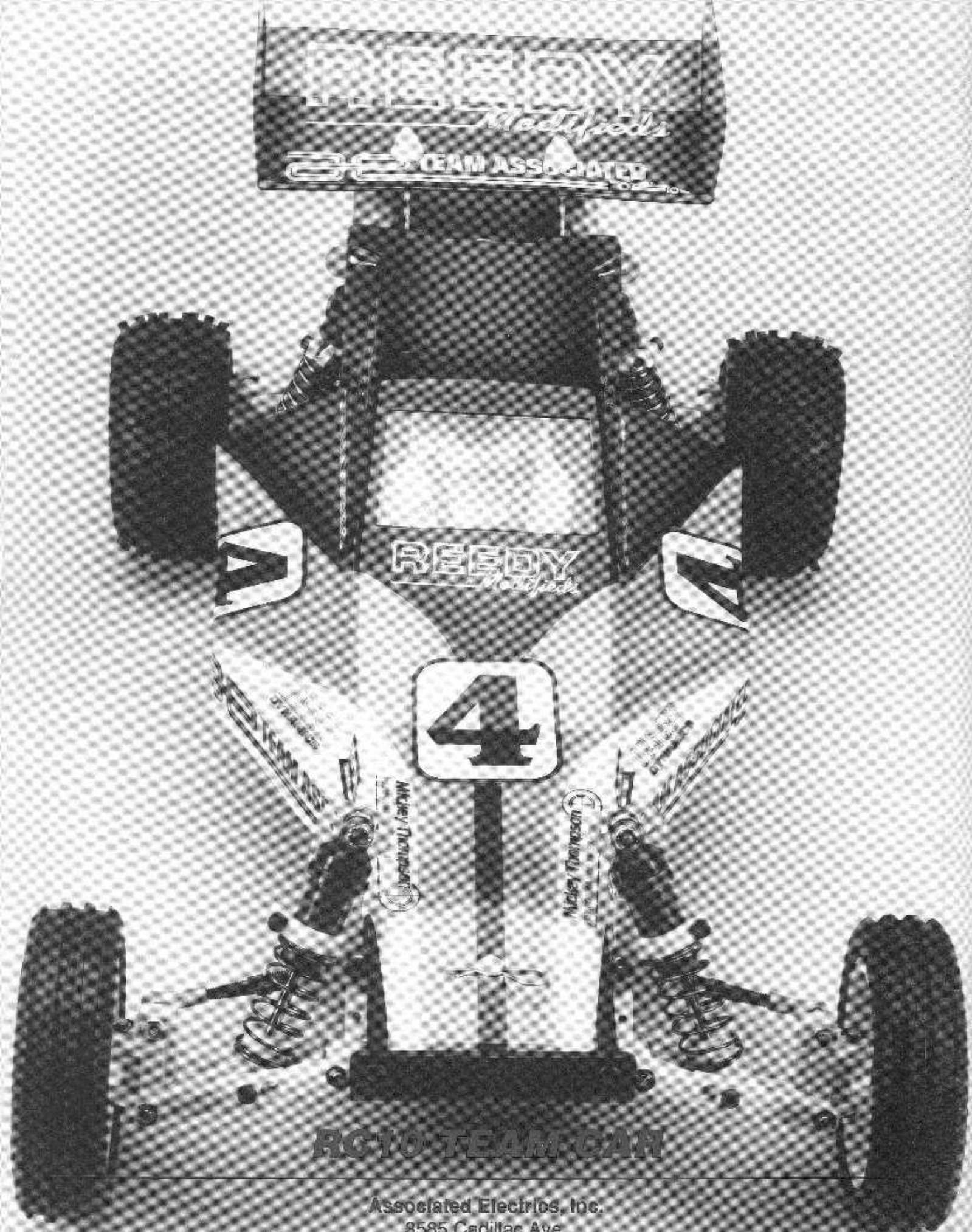

RC10 TEAM CAR

Associated Electricos, Inc.
8585 Cadillac Ave.
Costa Mesa, CA 92626 USA